

ADJUSTMENT

HINT:

- Use the same procedures for the RH side and LH side.

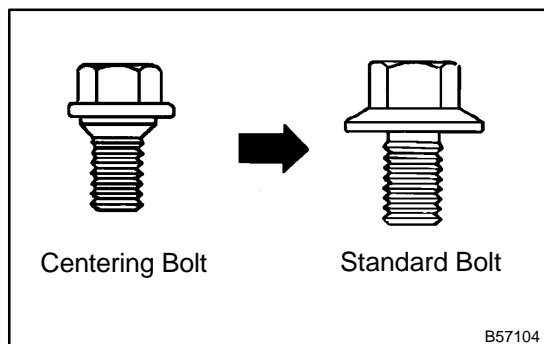

- Centering bolts are used to mount the door hinge to the vehicle body and door. The door cannot be adjusted with the centering bolts on. Substitute the centering bolts with standard bolts (w/ washers) when making adjustments.

1. INSPECT REAR DOOR PANEL SUB-ASSY LH

- (a) Check that the clearance is within the standard range.

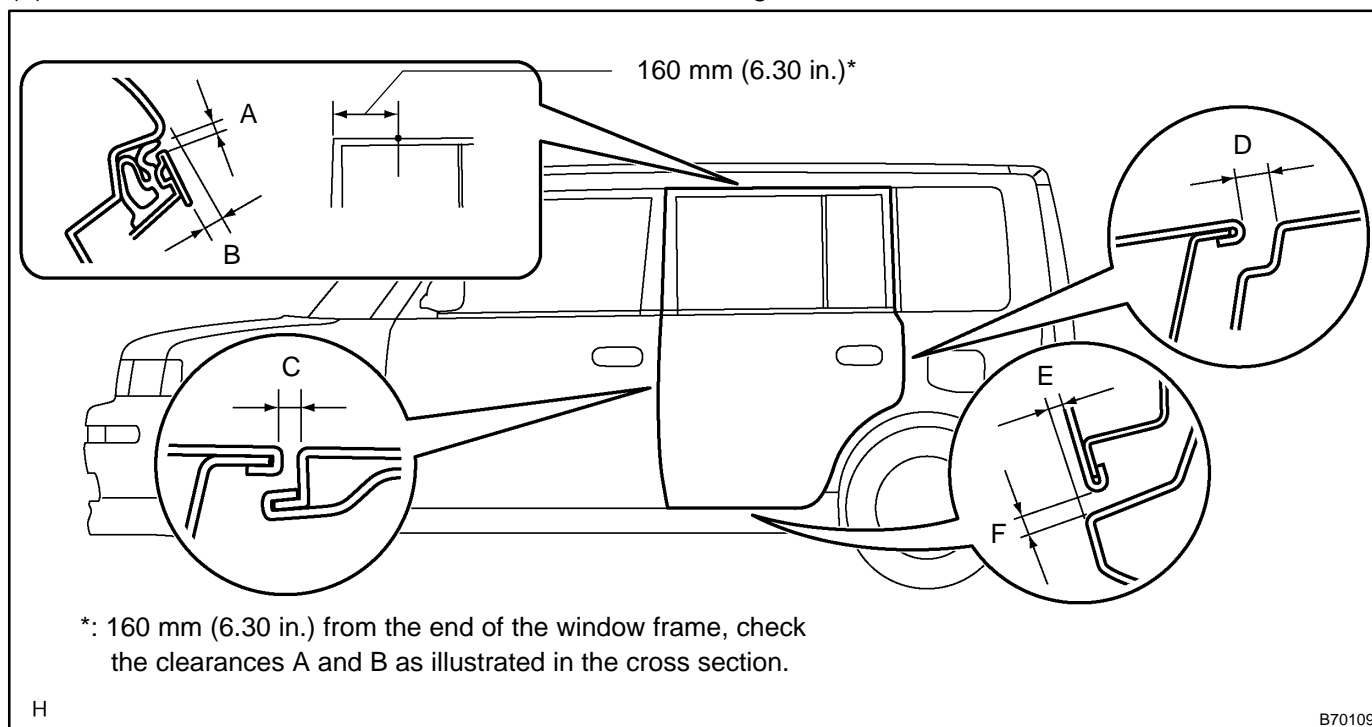

Standard:

Area	Measurement
A	5.2 ± 1.5 mm (0.205 ± 0.059 in.)
B	6.2 ± 1.5 mm (0.244 ± 0.059 in.)
C	5.4 ± 1.5 mm (0.213 ± 0.059 in.)
D	4.3 ± 0.0 mm (0.169 ± 0.000 in.)
E	6.4 ± 0.0 mm (0.252 ± 0.000 in.)
F	6.1 ± 1.5 mm (0.240 ± 0.059 in.)

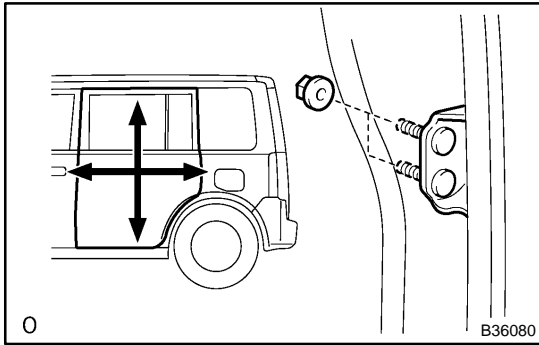

2. ADJUST REAR DOOR PANEL SUB-ASSY LH

- (a) Remove the lower garnish (See page 76-15).
- (b) As shown in the illustration, horizontally and vertically adjust the door by loosening the body side hinge nuts.
- (c) Tighten the body side hinge nuts after the adjustment.
Torque: 26 N·m (265 kgf·cm, 19 ft·lbf)

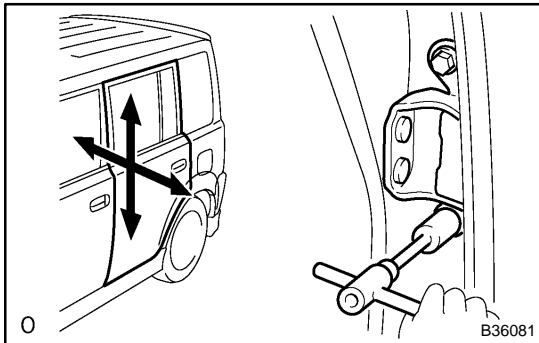

- (d) Horizontally and vertically adjust the door by loosening the door side hinge bolts.
- (e) Tighten the door side hinge bolts after the adjustment.
Torque: 26 N·m (265 kgf·cm, 19 ft·lbf)

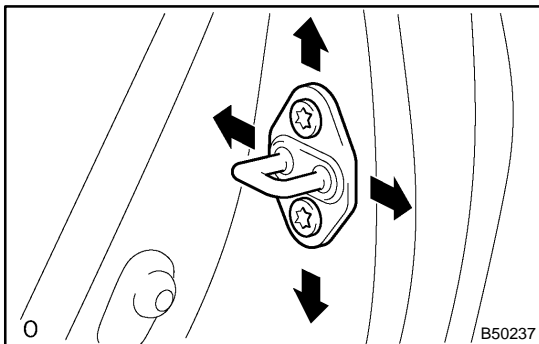

- (f) Adjust the striker position by slightly loosening the striker mounting screws and hitting the striker with a plastic-faced hammer.
- (g) Tighten the striker mounting screws after the adjustment.
Torque: 23 N·m (235 kgf·cm, 17 ft·lbf)