

DOOR CONTROL TRANSMITTER

INSPECTION

730E8-03

1. INSPECT DOOR CONTROL TRANSMITTER

- (a) Inspect operation of the transmitter.
- (1) Remove the battery (lithium battery) from the transmitter (See page 73-11).
 - (2) Install a new or normal battery (lithium battery).

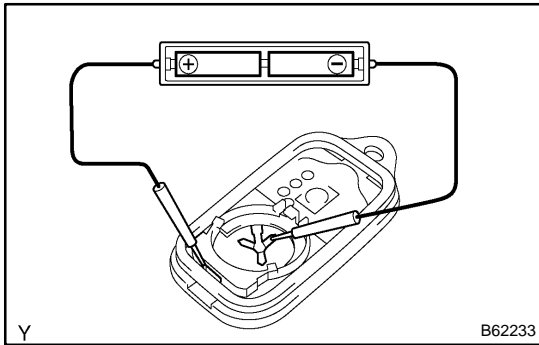

HINT:

When a new or normal battery is not available, connect 2 new 1.5 V batteries in series, connect the battery positive (+) to the battery receptacle side terminal and battery negative (-) to the bottom terminal, then apply 3 V of voltage to the transmitter.

- (3) In a location that is approx. 1 m (3.28 ft) away from the driver side outside door handle in the right direction, point the key plate of the transmitter at the vehicle and check operation of the transmitter by pressing the transmission switch on the transmitter body.

Standard:

The door lock can be operated via the remote control.

HINT:

- The minimum operational distance differs, depending on the operator, the way the transmitter is held, and the location.
 - Since the transmitter uses faint electric waves, the operational distance might be shortened if noise or strong electric wave occurs in the area where the frequency is used.
- (4) Install the battery (lithium battery).
- (b) Inspect the battery capacity.

HINT:

- The capacity of the battery can be determined only when the battery is installed in the transmitter. For a lithium battery used in the transmitter, a voltage of more than 2.5 V is shown on the tester until the energy is completely consumed, while no battery is installed in the transmitter. Therefore, it is necessary to measure the voltage while the battery is installed in the transmitter (a resistance of 1.2 k Ω is applied to the battery) when checking the amount of energy left in the battery.
 - If the transmitter is faulty, the amount of energy left in the battery might not be checked correctly.
- (1) Remove the battery (lithium battery) from the transmitter (See page 73-11).

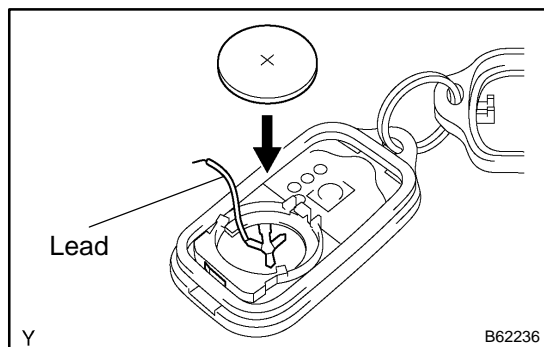

- (2) Connect the lead to the negative (–) terminal of the transmitter and install the battery.

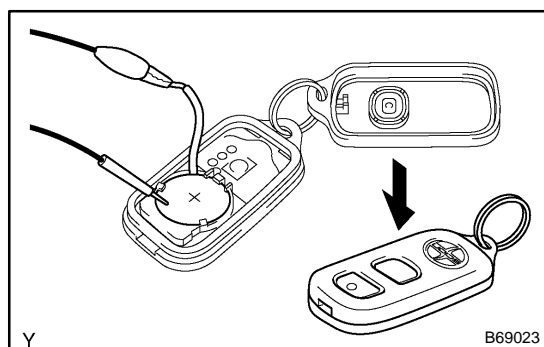

- (3) Connect the tester positive (+) probe to the positive (+) battery (lithium battery) and the tester negative (–) probe to the lead respectively.
- (4) Press one of the transmission switches on the transmitter for approx. 1 second.
- (5) Press the transmission switch on the transmitter again to check the voltage.

Standard: 2.2 V or higher

HINT:

- When the temperature of the battery is low, the inspection can not be made correctly. When the outcome of the test is less than 2.2 V, conduct the test again after leaving the battery in a place with a temperature of 18°C (64°F) for more than 30 minutes.
 - The automatic power-off function causes the voltage of the battery to be 2.5 V or more (a voltage with no resistance applied to the battery) when 0.8 seconds have passed after the switch is pressed. Therefore, make sure to read the voltage just after the switch is pressed.
 - Because high voltage might be shown once or twice after the battery returns to the specified temperature, the inspection should be made with the voltage shown after the switch is pressed at least 3 times.
- (6) Disconnect the lead.
 - (7) Set the battery (lithium battery) in the transmitter.