

WINDOW GLASS (ANTENNA WIRE) REPAIR

670VP-01

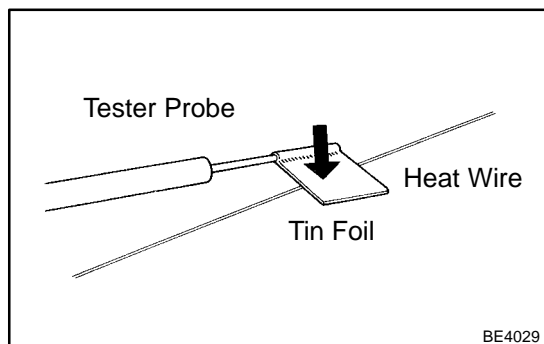

1. INSPECT WINDOW GLASS (ANTENNA WIRE)

NOTICE:

When cleaning the glass, use a soft, dry cloth, and wipe the glass in the direction of the wire. Be careful not to damage the wires. Do not use detergents or glass cleaners with abrasive ingredients. When measuring voltage, wind a piece of tin foil around the top of the negative probe and press the foil against the wire with your finger, as shown in the illustration.

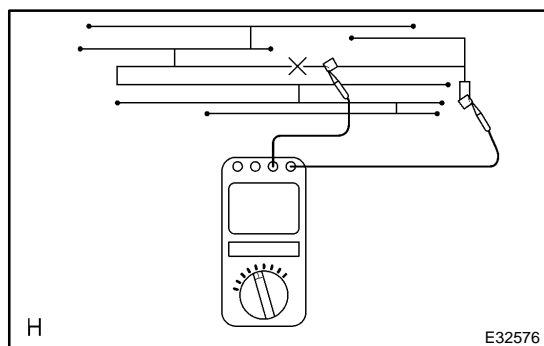

- (a) Inspect the continuity, at the center of each antenna wire, as shown in the illustration.

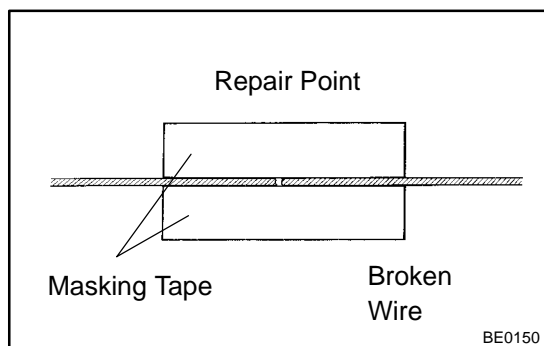

2. REPAIR WINDOW GLASS (ANTENNA WIRE)

- (a) Clean the broken wire tips with grease, wax and silicone remover.
- (b) Place masking tape along both sides of the wire to be repaired.
- (c) Thoroughly mix the repair agent (Dupont paste No.4817).

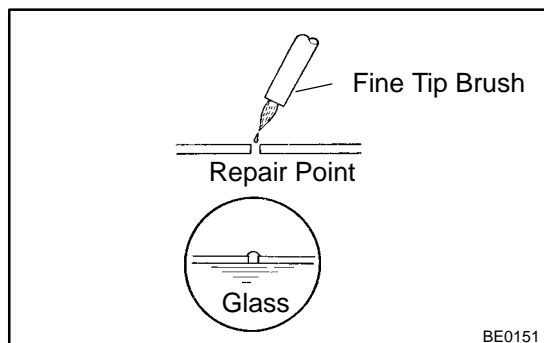

- (d) Using a fine tip brush, apply a small amount to the wire.
- (e) After a few minutes, remove the masking tape.
- (f) Do not repair the defogger wire for at least 24 hours.