

## OVERHAUL

### NOTICE:

- Do not overtighten when using a vise.
  - When installing, coat the parts indicated by arrows with power steering fluid (See page 51-7).
1. REMOVE FR WIPER ARM LH (See page 66-6)
  2. REMOVE FR WIPER ARM RH (See page 66-6)
  3. REMOVE HOOD TO COWL TOP SEAL (See page 66-6)
  4. REMOVE COWL TOP VENTILATOR LOUVER LH (See page 66-6)
  5. REMOVE COWL TOP VENTILATOR LOUVER RH (See page 66-6)
  6. REMOVE WINDSHIELD WIPER LINK ASSY (See page 66-6)
  7. REMOVE COWL PANEL SUB-ASSY (See page 55-42)
  8. REMOVE VANE PUMP OIL RESERVIOR COVER
  9. DRAIN POWER STEERING FLUID
  10. REMOVE FRONT WHEEL RH
  11. REMOVE ENGINE UNDER COVER RH

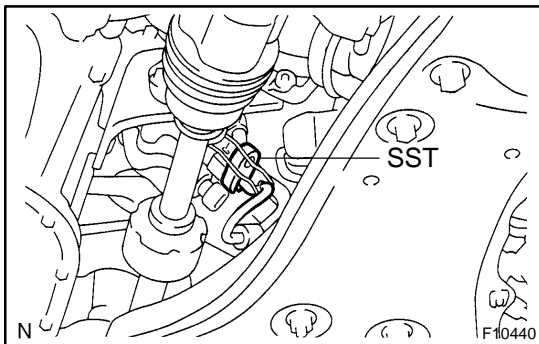

### 12. SEPARATE PRESSURE FEED TUBE ASSY

- (a) Using SST, disconnect the pressure feed tube assy from the vane pump assy.  
SST 09023-12700
- (b) Remove the clip and disconnect the return hose.

### NOTICE:

**Take care not to spill fluid on the V belt.**

- (c) Disconnect the oil pressure sensor connector.

### 13. REMOVE VANE PUMP STAY REAR

- (a) Remove the bolt, the stay rear and the heat insulator.

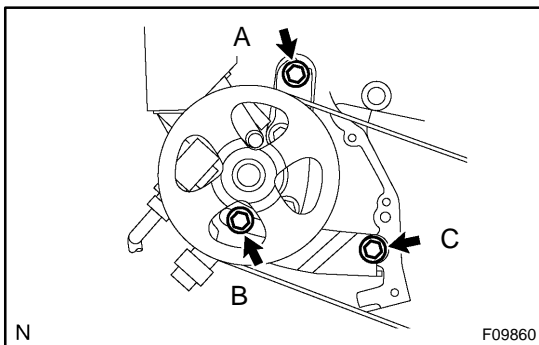

### 14. REMOVE VANE PUMP ASSY

- (a) Remove bolts B and C and the adjusting strut.
- (b) Loosen bolt A sufficiently so that the vane pump assy can be removed.

### HINT:

Bolt A cannot be removed.

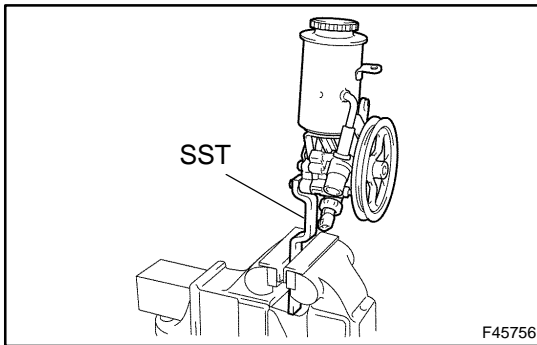
**15. FIX VANE PUMP ASSY**

- (a) Using SST, secure the vane pump assy in a vise.  
SST 09630-00014 (09631-00132)

**16. REMOVE VANE PUMP OIL RESERVOIR CAP SUB-ASSY****17. REMOVE VANE PUMP OIL RESERVOIR ASSY**

- (a) Remove the 3 bolts and the oil reservoir assy.  
(b) Remove the O-ring from the oil reservoir assy.

**18. REMOVE PUMP BRACKET FRONT**

- (a) Remove the 2 bolts, the bracket front and the bracket rear.

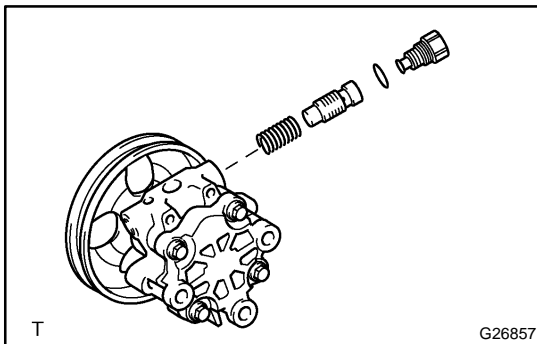
**19. REMOVE FLOW CONTROL VALVE**

- (a) Remove the pressure port union.  
(b) Remove the O-ring from the pressure port union.  
(c) Remove the flow control valve and the compression spring.

**20. REMOVE POWER STEERING OIL PRESSURE SENSOR**

- (a) Remove the oil pressure sensor from the housing front.

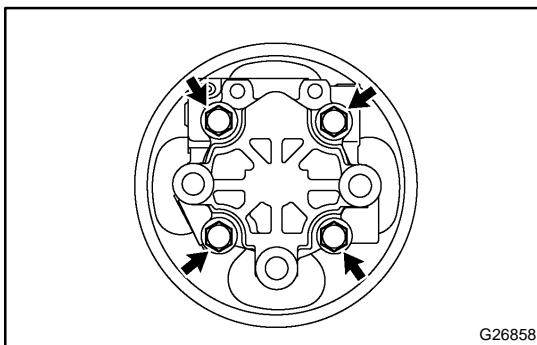
**21. REMOVE VANE PUMP HOUSING REAR**

- (a) Remove the 4 bolts and the housing rear from the housing front.  
(b) Remove the O-ring from the housing rear.

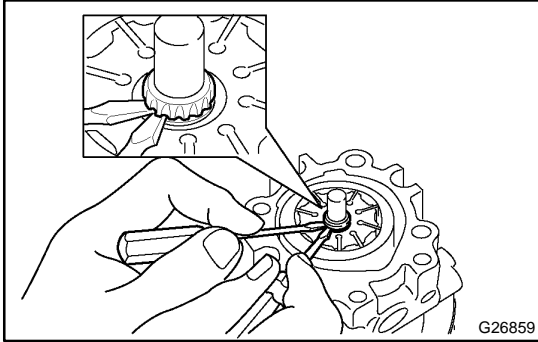
**22. REMOVE W/PULLEY SHAFT SUB-ASSY**

- (a) Using 2 screwdrivers, remove the snap ring from the w/pulley shaft sub-assy.
- (b) Remove the w/pulley shaft sub-assy.

**23. REMOVE VANE PUMP ROTOR**

- (a) Remove the 10 vane pump plates.
- (b) Remove the vane pump rotor.

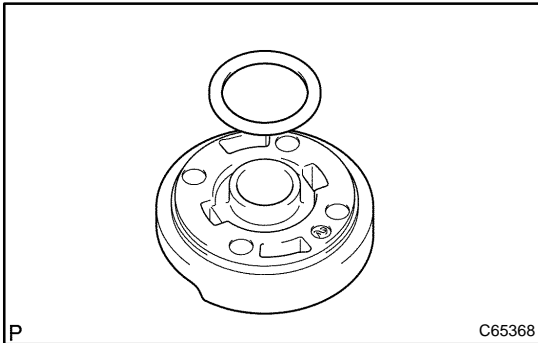
**24. REMOVE VANE PUMP CAM RING****25. REMOVE VANE PUMP SIDE PLATE FRONT**

- (a) Remove the side plate front from the housing front.
- (b) Remove the O-ring from the side plate front.

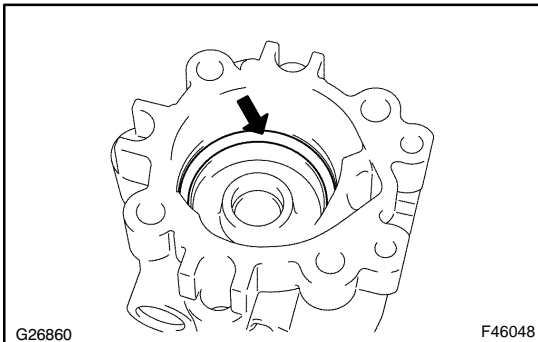

- (c) Remove the O-ring from the housing front.

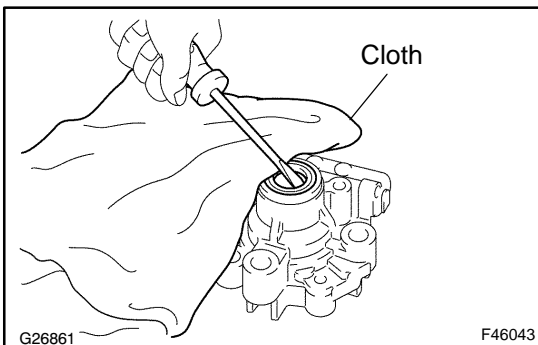
**26. REMOVE VANE PUMP HOUSING OIL SEAL**

- (a) Using a screwdriver and shop rag, remove the housing oil seal.

**NOTICE:**

**Be careful not to damage the housing front.**

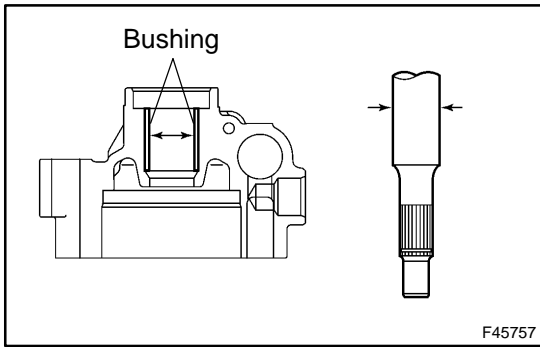

**27. INSPECT VANE PUMP SHAFT AND BUSH IN HOUSING FRONT**

- (a) Using a micrometer and a caliper gauge, measure the oil clearance.

**Maximum clearance: 0.07 mm (0.0028 in.) or less**

If the clearance exceeds the maximum, replace the vane pump assy.

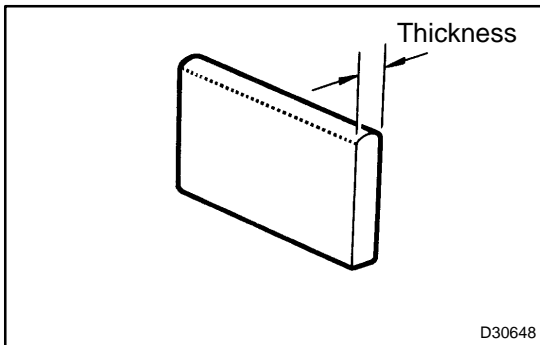

**28. INSPECT VANE PUMP ROTOR AND VANE PUMP PLATES**

- (a) Using a micrometer, measure the thickness of the vane pump plates.

**Minimum thickness:**

**1.405 to 1.411 mm (0.05531 to 0.05555 in.)**

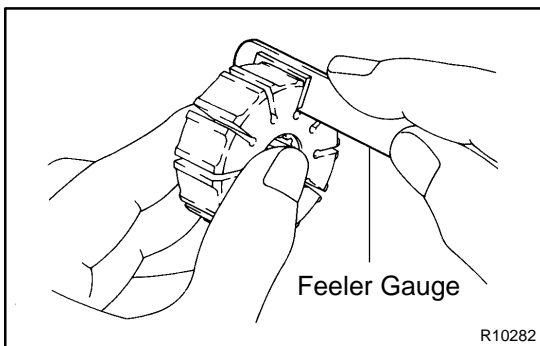

- (b) Using a feeler gauge, measure the clearance between a side face of the vane pump rotor groove and the vane plates.

**Maximum clearance: 0.03 mm (0.0012 in.)**

If the clearance exceeds the maximum, replace the vane pump assy.

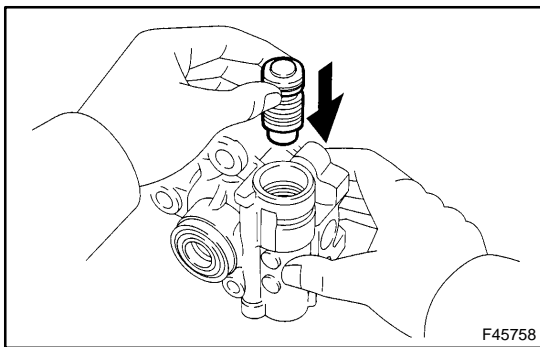

**29. INSPECT FLOW CONTROL VALVE**

- (a) Coat the flow control valve with power steering fluid and check that it falls smoothly into the flow control valve hole under its own weight.

If necessary, replace the vane pump assy.

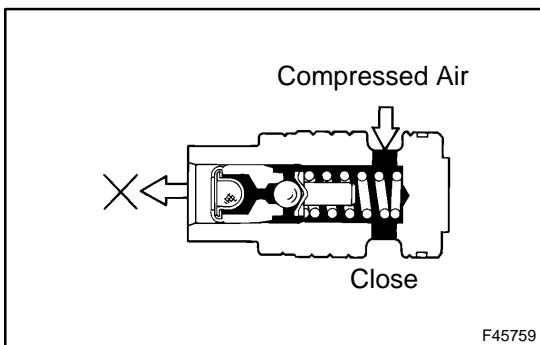

- (b) Check the flow control valve for leakage. Close one of the holes and apply compressed air of 392 to 490 kPa (4 to 5 kgf·cm<sup>2</sup>, 57 to 71 psi) into the opposite side hole, and confirm that air does not come out from the end holes.

If necessary, replace the vane pump assy.

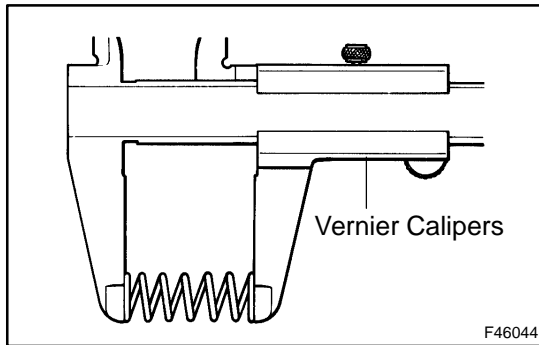

### 30. INSPECT FLOW CONTROL VALVE COMPRESSION SPRING

- (a) Using vernier calipers, measure the free length of the compression spring.

**Minimum free length: 29.2 mm (1.150 in.)**

If it is less than minimum, replace the vane pump Assy.

### 31. INSPECT PRESSURE PORT UNION

If the union seat in the pressure port union is severely damaged, it may cause fluid leakage. In that case, replace the vane pump Assy.

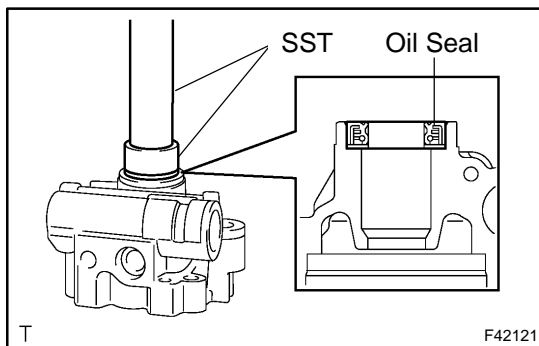

### 32. INSTALL VANE PUMP HOUSING OIL SEAL

- (a) Coat a new housing oil seal lip with power steering fluid.  
 (b) Using SST and a press, install a new housing oil seal.

SST 09950-60010 (09951-00280), 09950-70010 (09951-07100)

#### NOTICE:

**Make sure that the oil seal is installed correctly.**

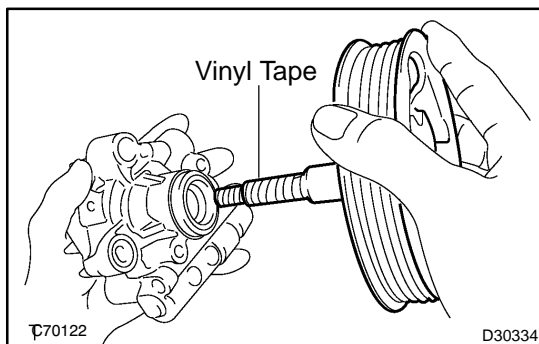

### 33. INSTALL W/PULLEY SHAFT SUB-ASSY

- (a) Coat inside bushing surface of the housing front with power steering fluid.  
 (b) Gradually insert the w/pulley shaft sub-assy.

#### NOTICE:

**Be careful not to damage the oil seal lip.**

#### HINT:

Wrap the shaft with vinyl tape before inserting.

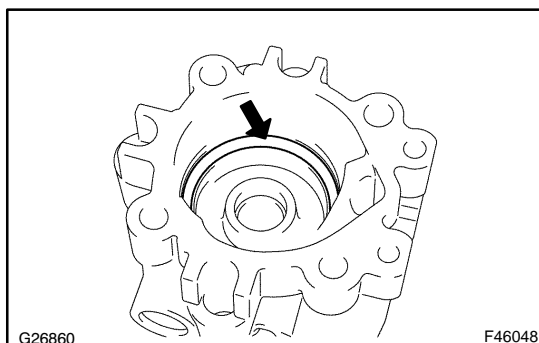

### 34. INSTALL VANE PUMP SIDE PLATE FRONT

- (a) Coat a new O-ring with power steering fluid and install it to the housing front.

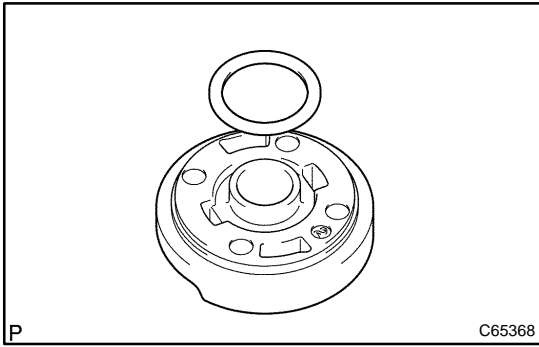

- (b) Coat a new O-ring with power steering fluid and install it to the side plate front.

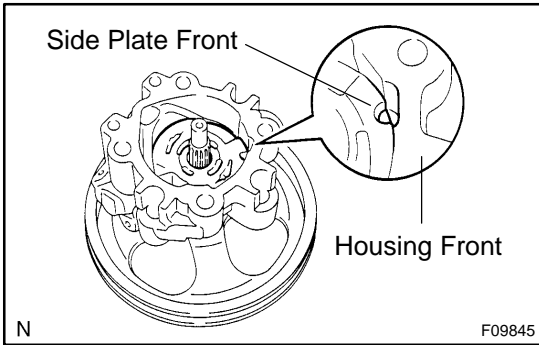

- (c) Align the dent of the side plate front with that of the housing front to install.

**NOTICE:**

**Make sure that the side plate front is installed correctly.**

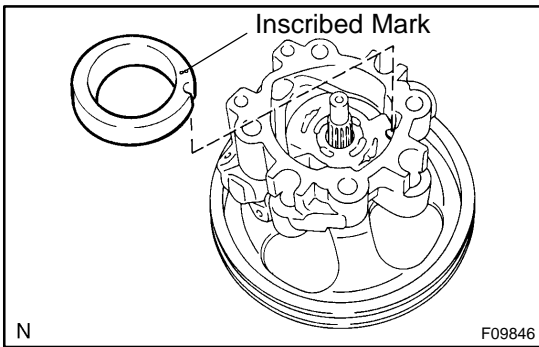

**35. INSTALL VANE PUMP CAM RING**

- (a) Align the dent of the cam ring with that of the side plate front, and install the cam ring with the inscribed mark facing upward.

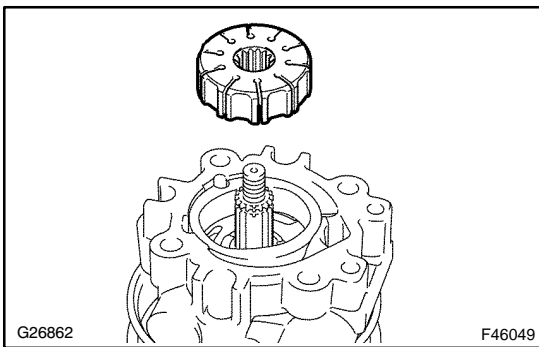

**36. INSTALL VANE PUMP ROTOR**

- (a) Install the vane pump rotor.

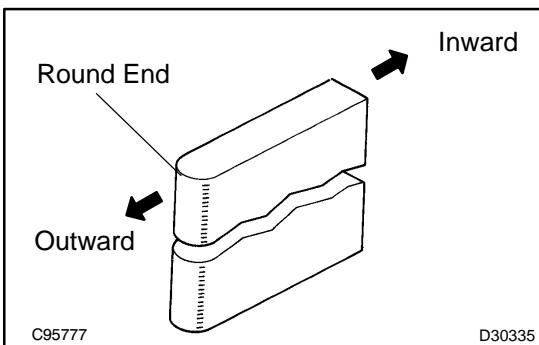

- (b) Apply power steering fluid to 10 vane pump plates.
- (c) Install the vane pump plates with the round end facing outward.

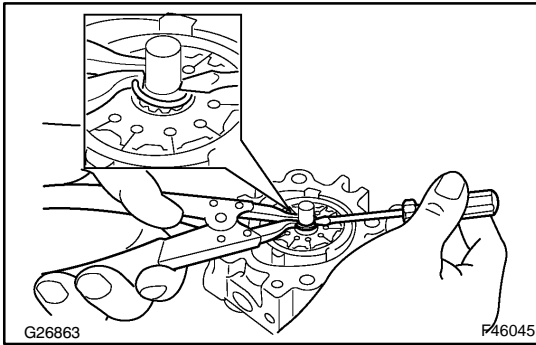
**37. INSTALL VANE PUMP SHAFT SNAP RING**

- (a) Using a screwdriver and a snap ring expander, install a new snap ring to the w/pulley shaft sub-assy.

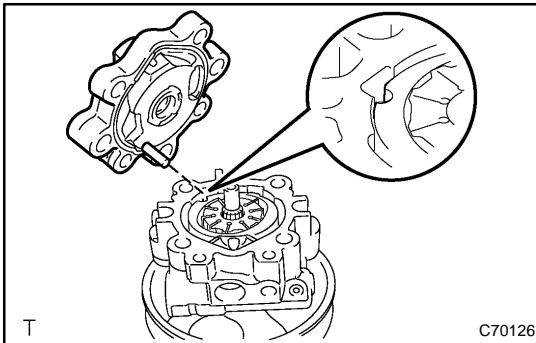
**38. INSTALL VANE PUMP HOUSING REAR**

- (a) Apply power steering fluid to a new O-ring and install it to the housing rear.
- (b) Align the straight pin of the housing rear with the dents of the cam ring, the side plate front and the housing front, and install the housing rear with the 4 bolts.

**Torque: 22 N·m (224 kgf·cm, 16 ft·lbf)**

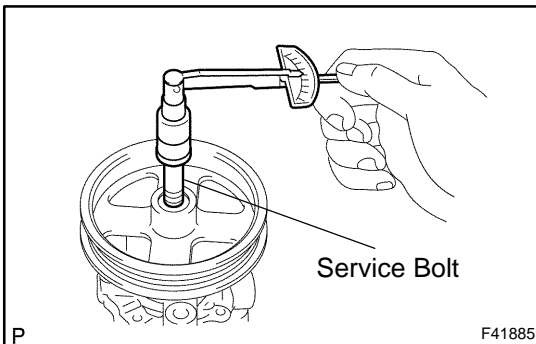
**39. INSPECT PRELOAD**

- (a) Check that the pump rotates smoothly without abnormal noise.

- (b) Temporarily install the service bolt.

**Recommended service bolt:**

**Thread diameter: 10 mm (0.39 in.)**

**Thread pitch: 1.25 mm (0.0492 in.)**

**Bolt length: 50 mm (1.97 in.)**

- (c) Using a torque wrench, check the pump rotating torque.

**Rotating torque:**

**0.27 N·m (2.8 kgf·cm, 2.4 in·lbf) or less**

If the rotating torque is not as specified, check installation of the housing oil seal.

**40. INSTALL POWER STEERING OIL PRESSURE SENSOR**

- (a) Apply power steering fluid to a new O-ring and install it to the oil pressure sensor.
- (b) Install the oil pressure sensor to the housing front.

**Torque: 21 N·m (214 kgf·cm, 15 ft·lbf)**

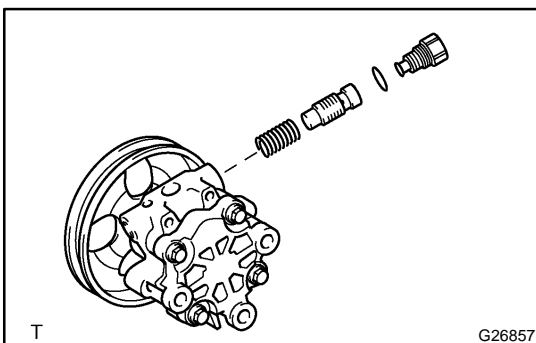
**41. INSTALL FLOW CONTROL VALVE**

- (a) Apply power steering fluid to the compression spring and the flow control valve.

- (b) Install the compression spring and the flow control valve.

- (c) Apply power steering fluid to a new O-ring and install it to the pressure port union.

- (d) Install the pressure port union.

**Torque: 69 N·m (704 kgf·cm, 51 ft·lbf)**

**42. INSTALL PUMP BRACKET FRONT**

- (a) Install the bracket front and the bracket rear with the 2 bolts.

**Torque: 44 N·m (449 kgf·cm, 32 ft·lbf)**

**43. INSTALL VANE PUMP OIL RESERVOIR ASSY**

- (a) Apply power steering fluid to a new O-ring and install it to the oil reservoir assy.  
 (b) Install the oil reservoir assy with the 3 bolts to the housing front.

**Torque: 9.0 N·m (92 kgf·cm, 80 in·lbf)**

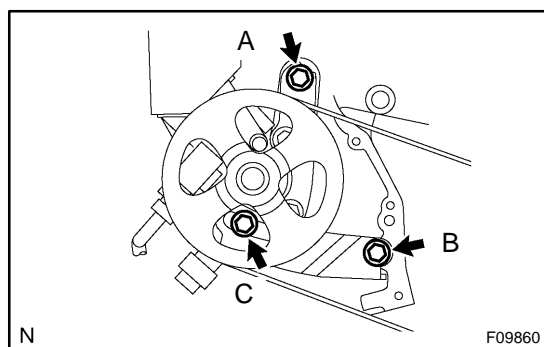
**44. INSTALL VANE PUMP OIL RESERVOIR CAP SUB-ASSY****45. INSTALL VANE PUMP ASSY**

- (a) Temporarily install the vane pump assy with bolt A.

HINT:

After adjusting the V belt tension, torque the bolt.

- (b) Install the adjusting strut with bolt B.

**Torque: 44 N·m (449 kgf·cm, 32 ft·lbf)**

- (c) Temporarily install bolt C.

HINT:

After adjusting the V belt tension, torque the bolt.

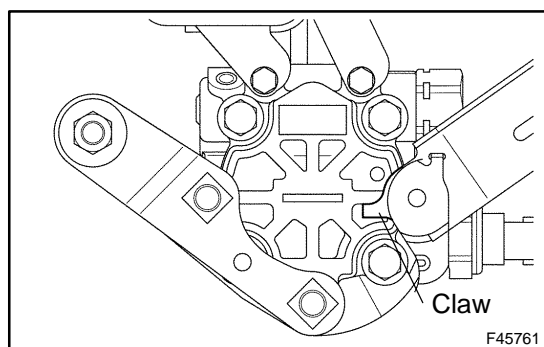
**46. INSTALL VANE PUMP STAY REAR**

- (a) Install the stay rear, to the housing rear, as shown in the illustration.

- (b) Install the heat insulator and the stay rear with the bolt.

**Torque: 44 N·m (449 kgf·cm, 32 ft·lbf)**

**NOTICE:**

Install the heat insulator by pressing its projection into a hole in the bracket rear, as shown in the illustration.

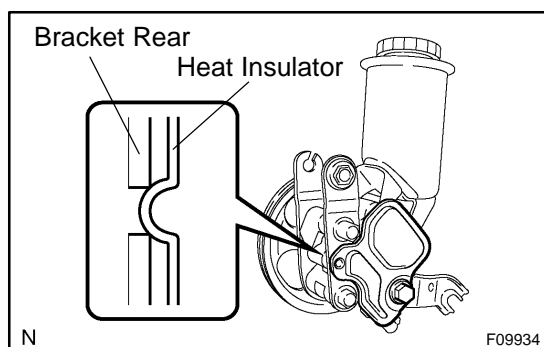
**47. CONNECT PRESSURE FEED TUBE ASSY**

- (a) Using SST, connect the pressure feed tube assy.  
 SST 09023-12700

**Torque: 41 N·m (414 kgf·cm, 30 ft·lbf)**

HINT:

- Use a torque wrench with a fulcrum length of 345 mm (13.58 in.).
- This torque value is effective when SST(s) is parallel to a torque wrench.

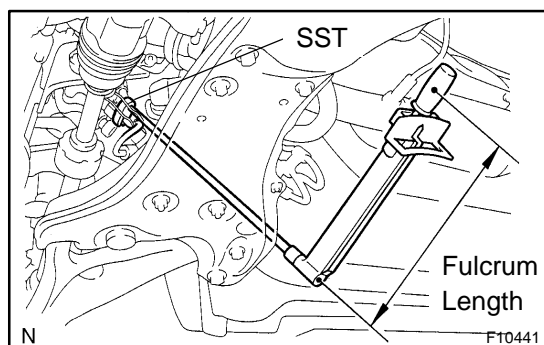

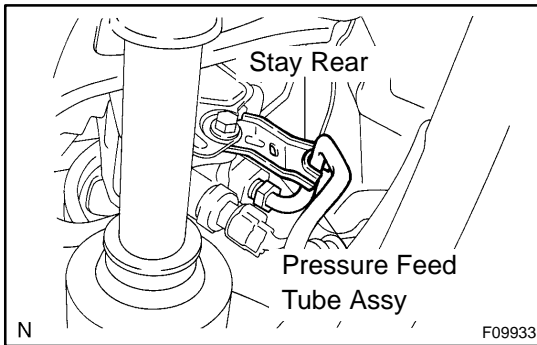

- (b) Check that the pressure feed tube assy is properly installed to the stay rear.
- (c) Connect the return hose with the clip.

**NOTICE:**

**Take care not to spill fluid on the V belt.**

- (d) Connect the oil pressure sensor connector.

- 48. ADJUST VANE PUMP V BELT (See page 14-5)
- 49. INSPECT DRIVE BELT DEFLECTION AND TENSION (REFERENCE) (See page 14-5)
- 50. ADD POWER STEERING FLUID (See page 51-3)
- 51. BLEED POWER STEERING FLUID (See page 51-3)
- 52. INSPECT FLUID LEAK
- 53. INSTALL ENGINE UNDER COVER RH
- 54. INSTALL FRONT WHEEL RH  
Torque: 103 N·m (1,050 kgf·cm, 76 ft·lbf)
- 55. CHECK POWER STEERING FLUID LEVEL IN RESERVOIR (See page 51-3)
- 56. INSTALL VANE PUMP OIL RESERVOIR COVER
- 57. INSTALL COWL PANEL SUB-ASSY (See page 55-42)
- 58. INSTALL WINDSHIELD WIPER LINK ASSY (See page 66-6)
- 59. INSTALL COWL TOP VENTILATOR LOUVER LH (See page 66-6)
- 60. INSTALL COWL TOP VENTILATOR LOUVER RH (See page 66-6)
- 61. INSTALL HOOD TO COWL TOP SEAL (See page 66-6)
- 62. INSTALL FR WIPER ARM LH (See page 66-6)
- 63. INSTALL FR WIPER ARM RH (See page 66-6)