

COIL SPRING REAR LH

REPLACEMENT

270FF-01

HINT:

COMPONENTS: See page 27-3

1. REMOVE REAR WHEEL

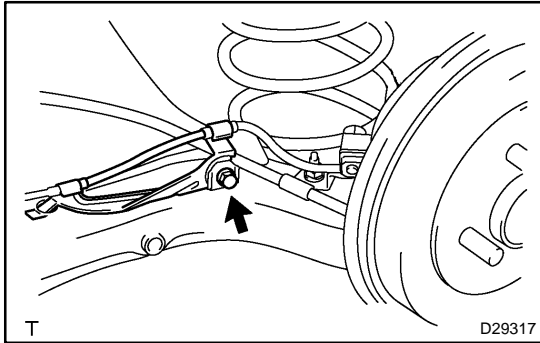

2. SEPARATE SKID CONTROL SENSOR WIRE

- (a) Disconnect the skid control sensor connector.

- (b) Remove the bolt and separate the skid control sensor wire from the axle beam.

HINT:

Separation of the RH is the same as that of the LH

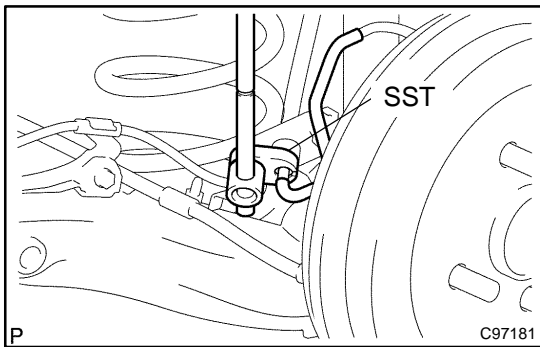

3. SEPARATE REAR BRAKE TUBE NO.4

- (a) Using SST, separate the rear brake tube No.4.
SST 09023-00100
- (b) Remove the clip.

NOTICE:**The clip should not be reused.**

4. SEPARATE REAR BRAKE TUBE NO.3

SST 09023-00100

HINT:

Disconnection of the rear brake tube No.3 is the same as that of the rear brake tube No.4.

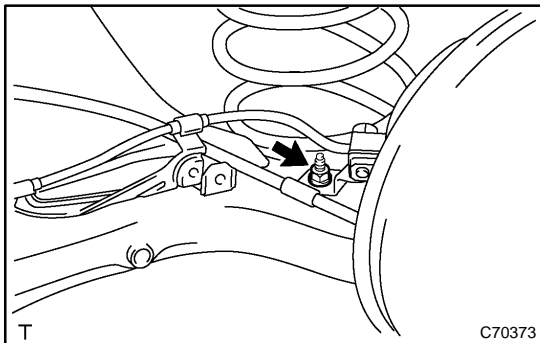

5. SEPARATE PARKING BRAKE CABLE ASSY NO.3

- (a) Remove the nut and disconnect the parking brake cable assy No.3 from the axle beam.

6. SEPARATE PARKING BRAKE CABLE ASSY NO.2

HINT:

Separation of the parking brake cable assy No.2 is the same as that of the parking brake cable assy No.3.

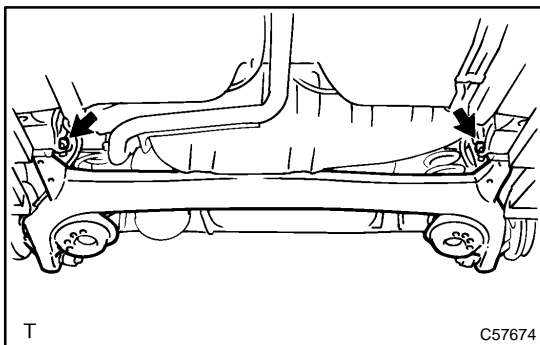
**7. LOOSEN REAR AXLE BEAM ASSY**

- (a) Loosen the 2 bolts.

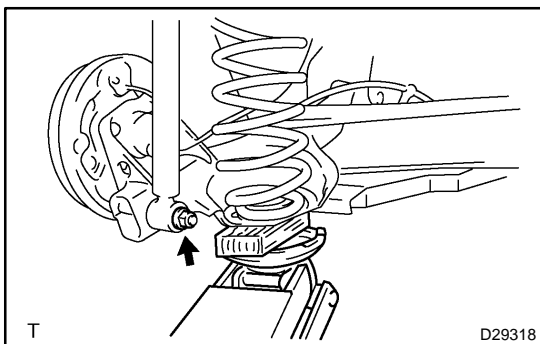
**8. SEPARATE SHOCK ABSORBER ASSY REAR LH**

- (a) Support the right and left sides of the rear axle beam with jacks.
 (b) Remove the nut and the washer, and separate the shock absorber assy rear LH.

9. SEPARATE SHOCK ABSORBER ASSY REAR RH

HINT:

Removal of the RH is the same as that of the LH.

10. REMOVE COIL SPRING REAR LH

- (a) Remove the coil spring LH, the upper insulator and the lower insulator by slowly lowering the jack.

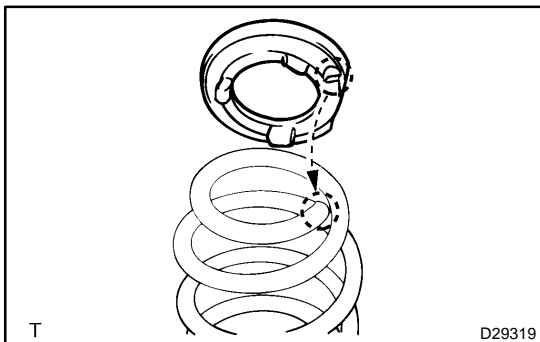
**11. INSTALL COIL SPRING REAR LH**

- (a) Install the rear coil spring insulator upper so that its gap fits to the end of the coil spring rear LH.

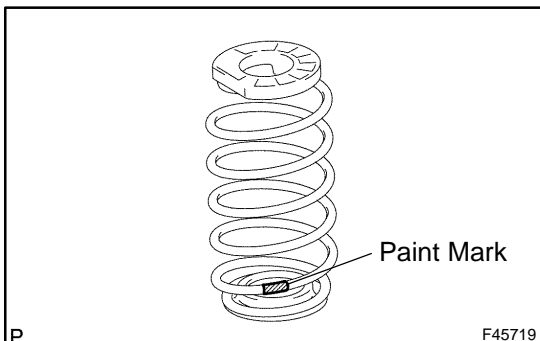

- (b) Install the rear coil spring insulator lower and the coil spring rear LH to the rear axle beam.

NOTICE:

Be sure to install the coil spring so that the paint mark comes to under the vehicle.

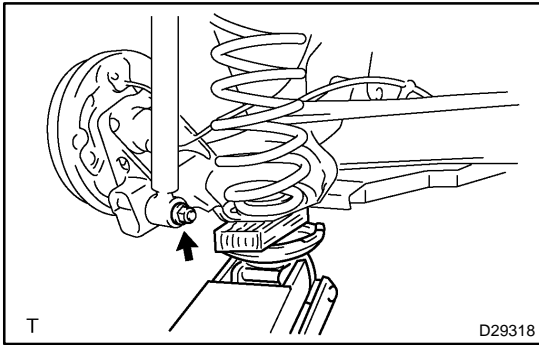

12. TEMPORARILY TIGHTEN SHOCK ABSORBER ASSY REAR LH

- While lifting the jacks, install the shock absorber assy rear LH to the rear axle beam.
- Temporarily tighten the nut and the washer.

13. TEMPORARILY TIGHTEN SHOCK ABSORBER ASSY REAR RH

HINT:

Connection of the RH is the same as that of the LH.

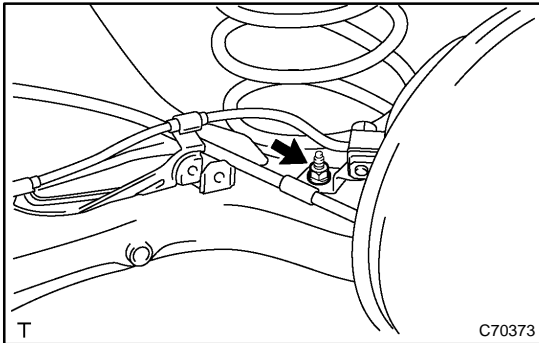

14. CONNECT PARKING BRAKE CABLE ASSY NO.3

- Install the parking brake cable assy No.3 with the nut.
Torque: 5.4 N·m (55 kgf·cm, 48 in.-lbf)

15. CONNECT PARKING BRAKE CABLE ASSY NO.2

HINT:

Connection of the RH is the same as that of the LH.

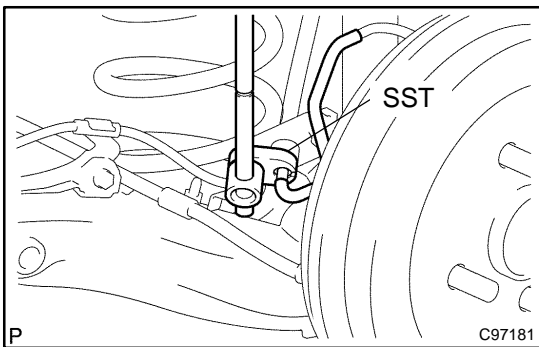

16. CONNECT REAR BRAKE TUBE NO.4

- Using SST, connect the brake line to the flexible hose.
SST 09023-00100
Torque: 15 N·m (155 kgf·cm, 11 ft·lbf)
- Install the clip.

17. CONNECT REAR BRAKE TUBE NO.3

SST 09023-00100

HINT:

Connection of the rear brake tube No.3 is the same as that of the rear brake tube No.4.

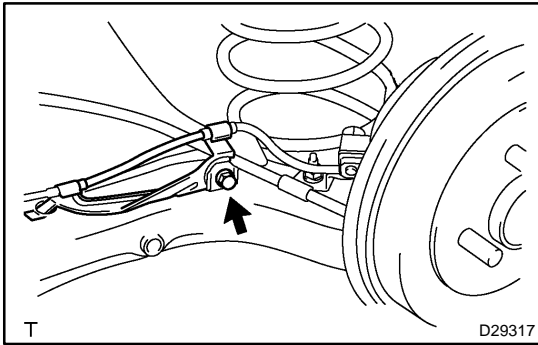
**18. CONNECT SKID CONTROL SENSOR WIRE**

- (a) Install the skid control sensor wire with the bolt.
Torque: 8.0 N·m (82 kgf·cm, 71 in·lbf)
- (b) Connect the skid control sensor wire.

HINT:

Connection of the RH side is the same as that of the LH side.

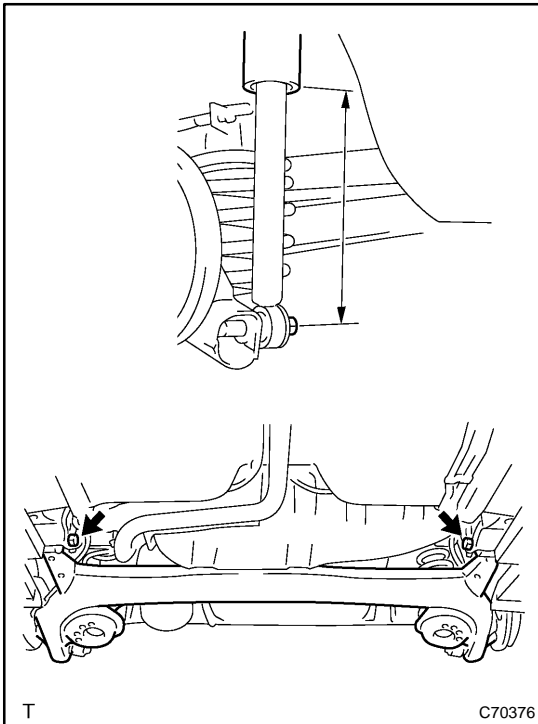
**19. FULLY TIGHTEN REAR AXLE BEAM ASSY**

- (a) Stabilize the shock absorber assy.

If the bolt cannot be tightened at this position, support the rear axle beam with the jack and load the rear compartment with a mass of approximately 90 kg (198 lb.)

Length of shock absorber: 250 mm (9.8 in.)

- (b) Fully tighten the bolt.

Torque: 82 N·m (836 kgf·cm, 60 ft·lbf)

20. FULLY TIGHTEN SHOCK ABSORBER ASSY REAR LH

- (a) Fully tighten the nut.

Torque: 49 N·m (500 kgf·cm, 36 ft·lbf)

21. FULLY TIGHTEN SHOCK ABSORBER ASSY REAR RH

HINT:

Installation of the RH is the same as that of the LH.

22. BLEED BRAKE LINE (See page 32-4)**23. INSTALL REAR WHEEL**

Torque: 103 N·m (1,050 kgf·cm, 76 ft·lbf)

24. INSPECT REAR WHEEL ALIGNMENT (See page 27-2)**25. CHECK ABS SPEED SENSOR SIGNAL (See page 05-269)**