

DTC	B0102/11	SHORT IN D SQUIB CIRCUIT (TO GROUND)
------------	-----------------	---

CIRCUIT DESCRIPTION

The D squib circuit consists of the airbag sensor assy center, the spiral cable sub-assy and the horn button assy.

This circuit instructs the SRS to deploy when deployment conditions are met.

DTC B0102/11 is recorded when a short to ground is detected in the D squib circuit.

DTC No.	DTC Detecting Condition	Trouble Area
B0102/11	<ul style="list-style-type: none"> • Short circuit in D squib wire harness (to ground) • D squib malfunction • Spiral cable sub-assy malfunction • Airbag sensor assy center malfunction 	<ul style="list-style-type: none"> • Horn button assy (D squib) • Spiral cable sub-assy • Airbag sensor assy center • Instrument panel wire

WIRING DIAGRAM

See page 05-464.

INSPECTION PROCEDURE

1	CHECK D SQUIB CIRCUIT(AIRBAG SENSOR ASSY CENTER – HORN BUTTON ASSY)
----------	--

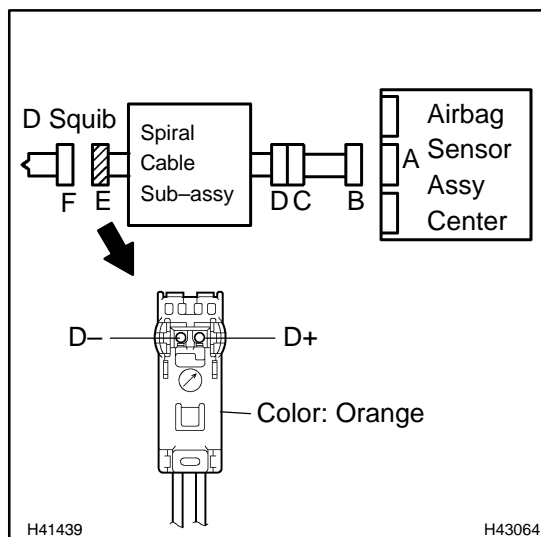

- Turn the ignition switch to the LOCK position.
- Disconnect the negative (–) terminal cable from the battery, and wait for at least 90 seconds.
- Disconnect the connectors from the airbag sensor assy center and the horn button assy.
- Measure the resistance according to the value(s) in the table below.

Standard:

Tester connection (Connector "E")	Condition	Specified condition
D+ – Body ground	Always	1 MΩ or Higher
D– – Body ground	Always	1 MΩ or Higher

NG

Go to step 5

OK

2 CHECK AIR BAG SENSOR ASSY CENTER

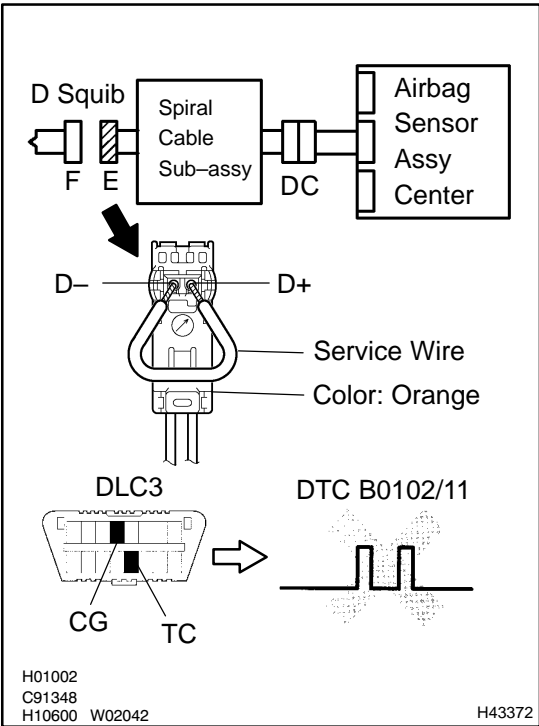

- (a) Connect the connector to the airbag sensor assy center.
- (b) Using a service wire, connect terminals D+ and D- of connector "E".

NOTICE:

- **Twist the end of the service wire in order to insert to the connector.**
 - **Do not forcibly insert the twisted service wire into the terminals of the connector when connecting.**
- (c) Connect the negative (-) terminal cable to the battery, and wait for at least 2 seconds.
 - (d) Turn the ignition switch to the ON position, and wait for at least 60 seconds.
 - (e) Clear the stored DTCs in the memory (See page 05-453).
 - (f) Turn the ignition switch to the LOCK position.
 - (g) Turn the ignition switch to the ON position, and wait for at least 60 seconds.
 - (h) Check the DTCs (See page 05-453).

OK:
DTC B0102/11 is not output.

HINT:
 Codes other than code B0102/11 may be output at this time, but they are not related to this check.

NG **REPLACE AIR BAG SENSOR ASSY CENTER**

OK

3 CHECK HORN BUTTON ASSY(D SQUIB)

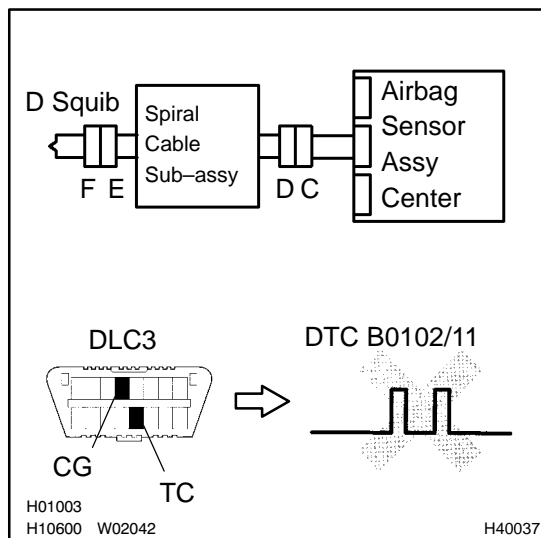

- (a) Turn the ignition switch to the LOCK position.
- (b) Disconnect the negative (-) terminal cable from the battery, and wait for at least 90 seconds.
- (c) Disconnect the service wire from the connector "E".
- (d) Connect the connectors to the horn button assy.
- (e) Connect the negative (-) terminal cable to the battery, and wait for at least 2 seconds.
- (f) Turn the ignition switch to the ON position, and wait for at least 60 seconds.
- (g) Clear the stored DTCs in the memory (See page [05-453](#)).
- (h) Turn the ignition switch to the LOCK position.
- (i) Turn the ignition switch to the ON position, and wait for at least for 60 seconds.
- (j) Check the DTCs (See page [05-453](#)).

OK:

DTC B0102/11 is not output.

HINT:

Codes other than code B0102/11 may be output at this time, but they are not related to this check.

NG

REPLACE HORN BUTTON ASSY

OK

4 USE SIMULATION METHOD TO CHECK

NG

Go to step 1

OK

REPLACE ALL SRS COMPONENTS INCLUDING WIRE HARNESS

5 CHECK INSTRUMENT PANEL WIRE

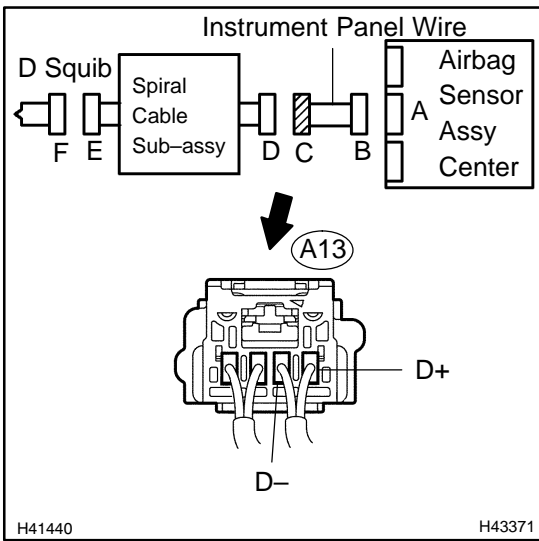

- (a) Disconnect the instrument panel wire connector from the spiral cable sub-assy.
- (b) Measure the resistance according to the value(s) in the table below.

Standard:

Tester connection (Connector "C")	Condition	Specified condition
A13-1 (D+) - Body ground	Always	1 MΩ or Higher
A13-2 (D-) - Body ground	Always	1 MΩ or Higher

NG REPAIR OR REPLACE INSTRUMENT PANEL WIRE

OK

6 CHECK SPIRAL CABLE SUB-ASSY

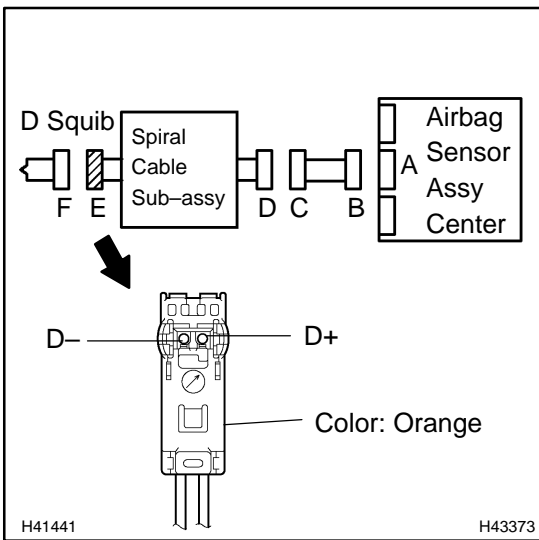

- (a) Measure the resistance according to the value(s) in the table below.

Standard:

Tester connection (Connector "E")	Condition	Specified condition
D+ - Body ground	Always	1 MΩ or Higher
D- - Body ground	Always	1 MΩ or Higher

NG REPLACE SPIRAL CABLE SUB-ASSY

OK

7 USE SIMULATION METHOD TO CHECK

NG Go to step 1

OK

REPLACE ALL SRS COMPONENTS INCLUDING WIRE HARNESS