

DTC	B0103/12	SHORT IN D SQUIB CIRCUIT (TO B+)
------------	-----------------	---

CIRCUIT DESCRIPTION

The D squib circuit consists of the airbag sensor assy center, the spiral cable sub-assy and the horn button assy.

This circuit instructs the SRS to deploy when deployment conditions are met.

DTC B0103/12 is recorded when a short to B+ is detected in the D squib circuit.

DTC No.	DTC Detecting Condition	Trouble Area
B0103/12	<ul style="list-style-type: none"> • Short circuit in D squib wire harness (to B+) • D squib malfunction • Spiral cable sub-assy malfunction • Airbag sensor assy center malfunction 	<ul style="list-style-type: none"> • Horn button assy (D squib) • Spiral cable sub-assy • Airbag sensor assy center • Instrument panel wire

WIRING DIAGRAM

See page 05-464.

INSPECTION PROCEDURE

1	CHECK D SQUIB CIRCUIT(AIRBAG SENSOR ASSY CENTER – HORN BUTTON ASSY)
----------	--

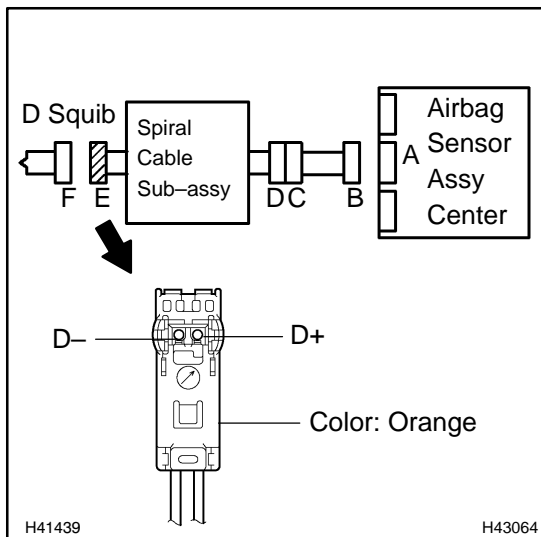

- (a) Turn the ignition switch to the LOCK position.
- (b) Disconnect the negative (-) terminal cable from the battery, and wait for at least 90 seconds.
- (c) Disconnect the connectors from the airbag sensor assy center and the horn button assy.
- (d) Connect the negative (-) terminal cable to the battery, and wait for at least 2 seconds.
- (e) Measure the voltage according to the value(s) in the table below.

Standard:

Tester connection (Connector "E")	Condition	Specified condition
D+ – Body ground	Ignition switch ON	Below 1 V
D- – Body ground	Ignition switch ON	Below 1 V

NG	Go to step 5
-----------	---------------------

OK

2 CHECK AIR BAG SENSOR ASSY CENTER

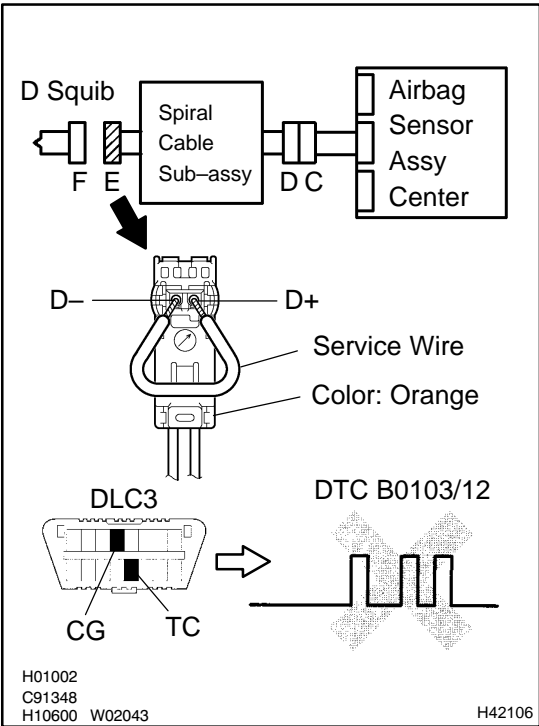

- (a) Turn the ignition switch to the LOCK position.
- (b) Disconnect the negative (-) terminal cable from the battery, and wait for at least 90 seconds.
- (c) Connect the connector to the airbag sensor assy center.
- (d) Using a service wire, connect terminals D+ and D- of connector "E".

NOTICE:

- **Twist the end of the service wire in order to insert to the connector.**
 - **Do not forcibly insert the twisted service wire into the terminals of the connector when connecting.**
- (e) Connect the negative (-) terminal cable to the battery, and wait for at least 2 seconds.
 - (f) Turn the ignition switch to the ON position, and wait for at least 60 seconds.
 - (g) Clear the stored DTCs in the memory (See page 05-453).
 - (h) Turn the ignition switch to the LOCK position.
 - (i) Turn the ignition switch to the ON position, and wait for at least 60 seconds.
 - (j) Check the DTCs (See page 05-453).

OK:

DTC B0103/12 is not output.

HINT:

Codes other than code B0103/12 may be output at this time, but they are not related to this check.

NG **REPLACE AIR BAG SENSOR ASSY CENTER**

OK

3 CHECK HORN BUTTON ASSY(D SQUIB)

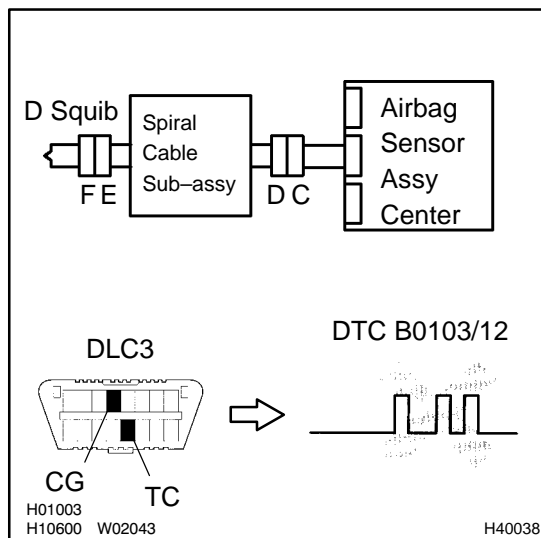

- Turn the ignition switch to the LOCK position.
- Disconnect the negative (-) terminal cable from the battery, and wait for at least 90 seconds.
- Disconnect the service wire from the connector "E".
- Connect the connectors to the horn button assy.
- Connect the negative (-) terminal cable to the battery, and wait for at least 2 seconds.
- Turn the ignition switch to the ON position, and wait for at least 60 seconds.
- Clear the stored DTCs in the memory (See page 05-453).
- Turn the ignition switch to the LOCK position.
- Turn the ignition switch to the ON position, and wait for at least 60 seconds.
- Check the DTCs (See page 05-453).

OK:

DTC B0103/12 is not output.

HINT:

Codes other than code B0103/12 may be output at this time, but they are not related to this check.

NG

REPLACE HORN BUTTON ASSY

OK

4 USE SIMULATION METHOD TO CHECK

NG

Go to step 1

OK

REPLACE ALL SRS COMPONENTS INCLUDING WIRE HARNESS

5 CHECK INSTRUMENT PANEL WIRE

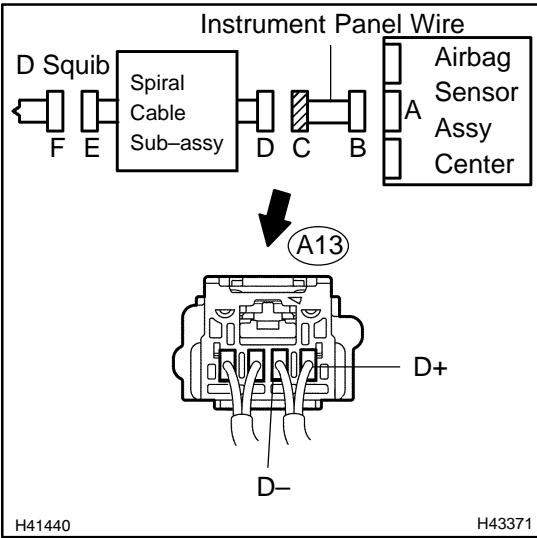

- (a) Turn the ignition switch to the LOCK position.
- (b) Disconnect the negative (-) terminal cable from the battery, and wait for at least 90 seconds.
- (c) Disconnect the instrument panel wire connector from the spiral cable sub-assy.
- (d) Connect the negative (-) terminal cable to the battery, and wait for at least 2 seconds.
- (e) Measure the voltage according to the value(s) in the table below.

Standard:

Tester connection (Connector "C")	Condition	Specified condition
A13-1 (D+) – Body ground	Ignition switch ON	Below 1 V
A13-2 (D-) – Body ground	Ignition switch ON	Below 1 V

NG REPAIR OR REPLACE INSTRUMENT PANEL WIRE

OK

6 CHECK SPIRAL CABLE SUB-ASSY

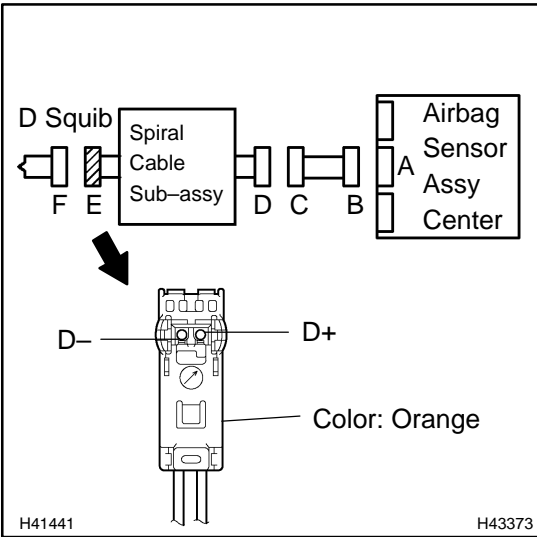

- (a) Measure the voltage according to the value(s) in the table below.

Standard:

Tester connection (Connector "E")	Condition	Specified condition
D+ – Body ground	Ignition switch ON	Below 1 V
D- – Body ground	Ignition switch ON	Below 1 V

NG REPLACE SPIRAL CABLE SUB-ASSY

OK

7 | **USE SIMULATION METHOD TO CHECK**

NG → **Go to step 1**

OK

REPLACE ALL SRS COMPONENTS INCLUDING WIRE HARNESS