

DTC	B1182/19	SHORT IN D SQUIB (2ND STEP) CIRCUIT (TO GROUND)
------------	-----------------	--

CIRCUIT DESCRIPTION

The D squib (2nd step) circuit consists of the airbag sensor assy center, the spiral cable sub-assy and the horn button assy.

This circuit instructs the SRS to deploy when deployment conditions are met.

DTC B1182/19 is recorded when a short to ground is detected in the D squib (2nd step) circuit.

DTC No.	DTC Detecting Condition	Trouble Area
B1182/19	<ul style="list-style-type: none"> • Short circuit in D squib (2nd step) wire harness (to ground) • D squib (2nd step) malfunction • Spiral cable sub-assy malfunction • Airbag sensor assy center malfunction 	<ul style="list-style-type: none"> • Horn button assy (D squib, 2nd step) • Spiral cable sub-assy • Airbag sensor assy center • Instrument panel wire

WIRING DIAGRAM

See page 05-548.

INSPECTION PROCEDURE

1	CHECK D SQUIB CIRCUIT(AIRBAG SENSOR ASSY CENTER – HORN BUTTON ASSY)
----------	--

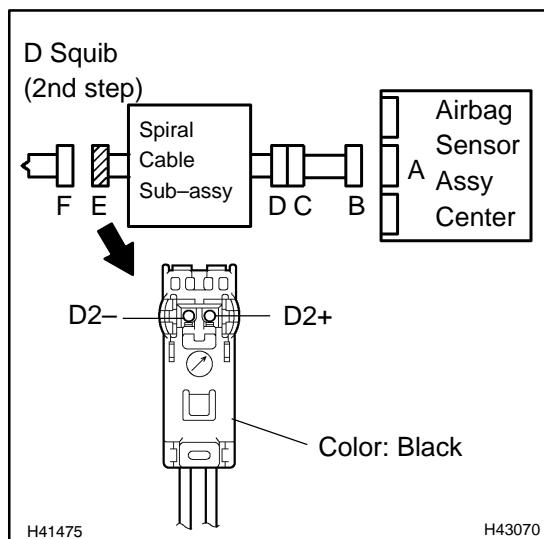

- (a) Turn the ignition switch to the LOCK position.
- (b) Disconnect the negative (-) terminal cable from the battery, and wait for at least 90 seconds.
- (c) Disconnect the connectors from the airbag sensor assy center and the horn button assy.
- (d) Measure the resistance according to the value(s) in the table below.

Standard:

Tester connection (Connector "E")	Condition	Specified condition
D2+ - Body ground	Always	1 MΩ or Higher
D2- - Body ground	Always	1 MΩ or Higher

NG	Go to step 5
-----------	---------------------

OK

2 CHECK AIR BAG SENSOR ASSY CENTER

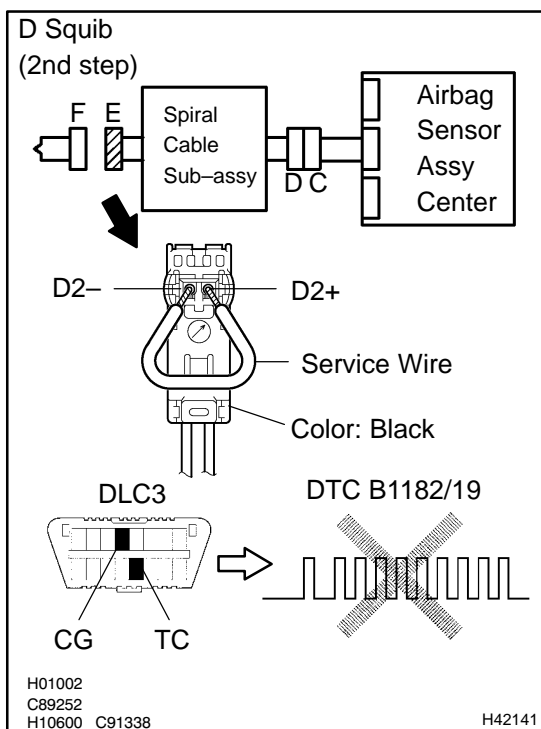

- Connect the connector to the airbag sensor assy center.
- Using a service wire, connect terminals D2+ and D2- of connector "E".

NOTICE:

- Twist the end of the service wire in order to insert to the connector.
 - Do not forcibly insert the twisted service wire into the terminals of the connector when connecting.
- Connect the negative (-) terminal cable to the battery, and wait for at least 2 seconds.
 - Turn the ignition switch to the ON position, and wait for at least 60 seconds.
 - Clear the stored DTCs in the memory (See page [05-453](#)).
 - Turn the ignition switch to the LOCK position.
 - Turn the ignition switch to the ON position, and wait for at least 60 seconds.
 - Check the DTCs (See page [05-453](#)).

OK:

DTC B1182/19 is not output.

HINT:

Codes other than code B1182/19 may be output at this time, but they are not related to this check.

NG

REPLACE AIR BAG SENSOR ASSY CENTER

OK

3 CHECK HORN BUTTON ASSY(D SQUIB, 2ND STEP)

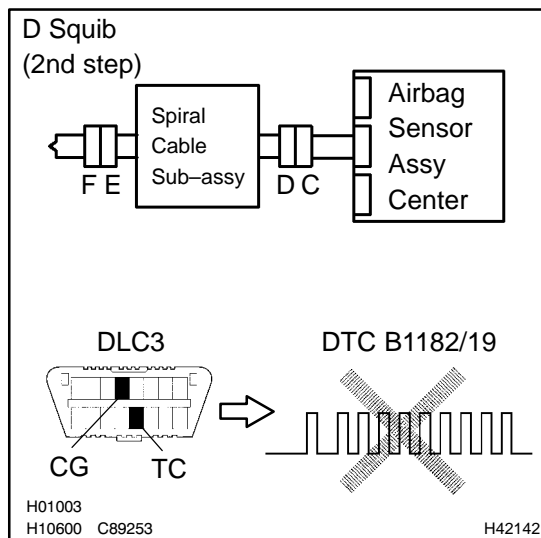

- Turn the ignition switch to the LOCK position.
- Disconnect the negative (-) terminal cable from the battery, and wait for at least 90 seconds.
- Disconnect the service wire from the connector "E".
- Connect the connectors to the horn button assy.
- Connect the negative (-) terminal cable to the battery, and wait for at least 2 seconds.
- Turn the ignition switch to the ON position, and wait for at least 60 seconds.
- Clear the stored DTCs in the memory (See page [05-453](#)).
- Turn the ignition switch to the LOCK position.
- Turn the ignition switch to the ON position, and wait for at least 60 seconds.
- Check the DTCs (See page [05-453](#)).

OK:

DTC B1182/19 is not output.

HINT:

Codes other than code B1182/19 may be output at this time, but they are not related to this check.

NG

REPLACE HORN BUTTON ASSY

OK

4 USE SIMULATION METHOD TO CHECK

NG

Go to step 1

OK

REPLACE ALL SRS COMPONENTS INCLUDING WIRE HARNESS

5 CHECK INSTRUMENT PANEL WIRE

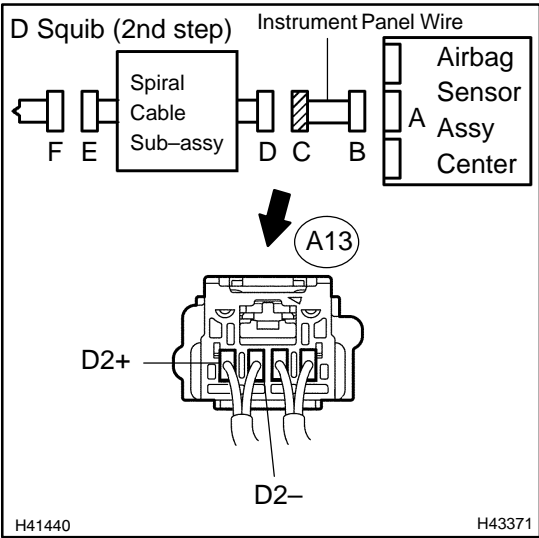

- (a) Disconnect the instrument panel wire connector from the spiral cable sub-assy.
- (b) Measure the resistance according to the value(s) in the table below.

Standard:

Tester connection (Connector "C")	Condition	Specified condition
A13-4 (D2+) - Body ground	Always	1 MΩ or Higher
A13-3 (D2-) - Body ground	Always	1 MΩ or Higher

NG REPAIR OR REPLACE INSTRUMENT PANEL WIRE

OK

6 CHECK SPIRAL CABLE SUB-ASSY

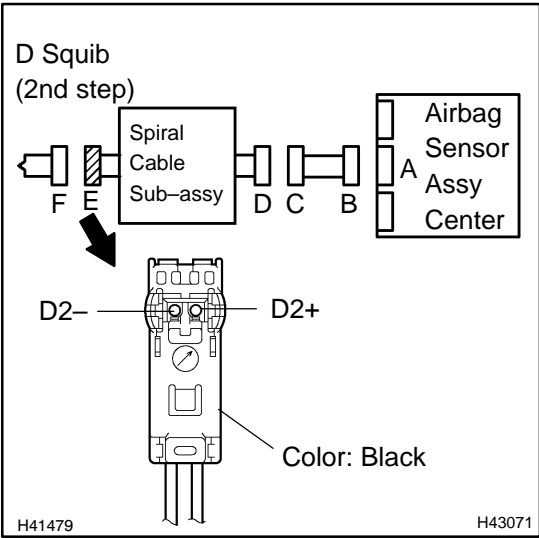

- (a) Measure the resistance according to the value(s) in the table below.

Standard:

Tester connection (Connector "E")	Condition	Specified condition
D2+ - Body ground	Always	1 MΩ or Higher
D2- - Body ground	Always	1 MΩ or Higher

NG REPLACE SPIRAL CABLE SUB-ASSY

OK

7 USE SIMULATION METHOD TO CHECK

NG Go to step 1

OK

REPLACE ALL SRS COMPONENTS INCLUDING WIRE HARNESS