

DTC	B1181/18	OPEN IN D SQUIB (2ND STEP) CIRCUIT
------------	-----------------	---

CIRCUIT DESCRIPTION

The D squib (2nd step) circuit consists of the airbag sensor assy center, the spiral cable sub-assy and the horn button assy.

This circuit instructs the SRS to deploy when deployment conditions are met.

DTC B1181/18 is recorded when an open circuit is detected in the D squib (2nd step) circuit.

DTC No.	DTC Detecting Condition	Trouble Area
B1181/18	<ul style="list-style-type: none"> • Open circuit in D2+ wire harness or D2- wire harness of D squib (2nd step) • D squib (2nd step) malfunction • Spiral cable sub-assy malfunction • Airbag sensor assy center malfunction 	<ul style="list-style-type: none"> • Horn button assy (D squib, 2nd step) • Spiral cable sub-assy • Airbag sensor assy center • Instrument panel wire

WIRING DIAGRAM

See page 05-548.

INSPECTION PROCEDURE

1	CHECK D SQUIB CIRCUIT(AIRBAG SENSOR ASSY CENTER – HORN BUTTON ASSY)
----------	--

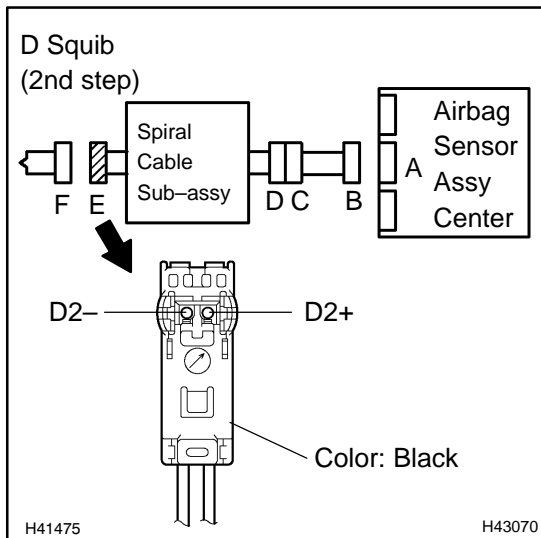

- (a) Turn the ignition switch to the LOCK position.
- (b) Disconnect the negative (-) terminal cable from the battery, and wait for at least 90 seconds.
- (c) Disconnect the connectors from the airbag sensor assy center and the horn button assy.
- (d) Measure the resistance according to the value(s) in the table below.

Standard:

Tester connection (Connector "E")	Condition	Specified condition
D2+ - D2-	Always	Below 1 Ω

NG	Go to step 4
-----------	---------------------

OK

2 CHECK AIR BAG SENSOR ASSY CENTER

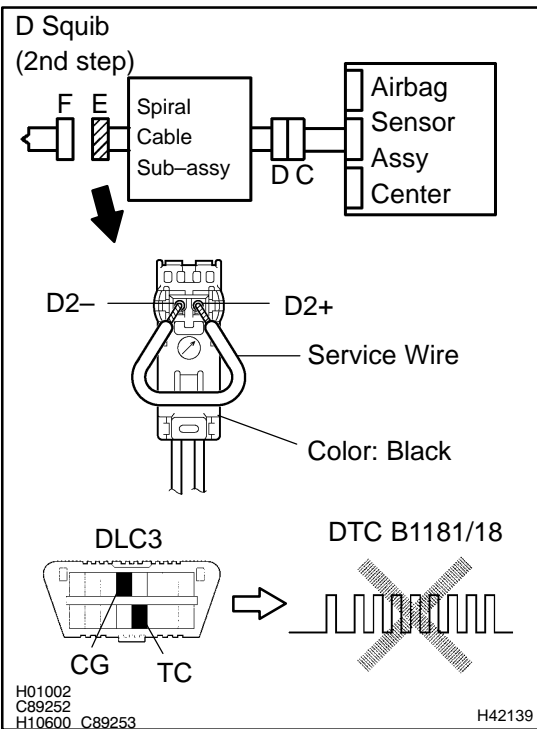

- (a) Connect the connector to the airbag sensor assy center.
- (b) Using a service wire, connect terminals D2+ and D2- of connector "E".

NOTICE:

- **Twist the end of the service wire in order to insert to the connector.**
 - **Do not forcibly insert the twisted service wire into the terminals of the connector when connecting.**
- (c) Connect the negative (-) terminal cable to the battery, and wait for at least 2 seconds.
 - (d) Turn the ignition switch to the ON position, and wait for at least 60 seconds.
 - (e) Clear the stored DTCs in the memory (See page 05-453).
 - (f) Turn the ignition switch to the LOCK position.
 - (g) Turn the ignition switch to the ON position, and wait for at least 60 seconds.
 - (h) Check the DTCs (See page 05-453).

OK:

DTC B1181/18 is not output.

HINT:

Codes other than code B1181/18 may be output at this time, but they are not related to this check.

NG **REPLACE AIR BAG SENSOR ASSY CENTER**

OK

3 CHECK HORN BUTTON ASSY(D SQUIB, 2ND STEP)

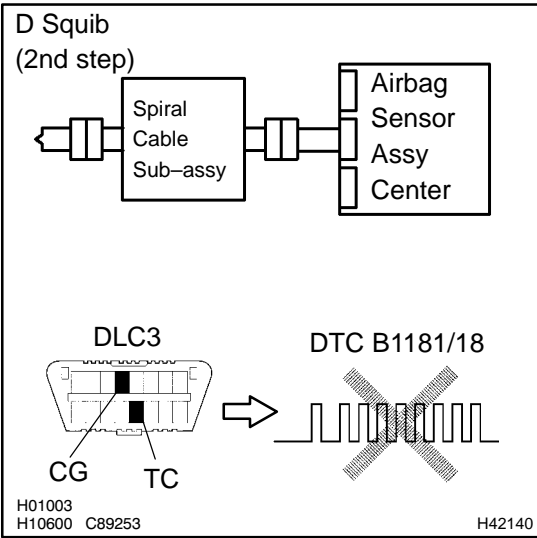

- (a) Turn the ignition switch to the LOCK position.
- (b) Disconnect the negative (-) terminal cable from the battery, and wait for at least 90 seconds.
- (c) Connect the connectors to the horn button assy.
- (d) Connect the negative (-) terminal cable to the battery, and wait for at least 2 seconds.
- (e) Turn the ignition switch to the ON position, and wait for at least 60 seconds.
- (f) Clear the stored DTCs in the memory (See page 05-453).
- (g) Turn the ignition switch to the LOCK position.
- (h) Turn the ignition switch to the ON position, and wait for at least 60 seconds.
- (i) Check the DTCs (See page 05-453).

OK:

DTC B1181/18 is not output.

HINT:

Codes other than code B1181/18 may be output at this time, but they are not related to this check.

NG → **REPLACE HORN BUTTON ASSY**

OK

USE SIMULATION METHOD TO CHECK

4 CHECK INSTRUMENT PANEL WIRE

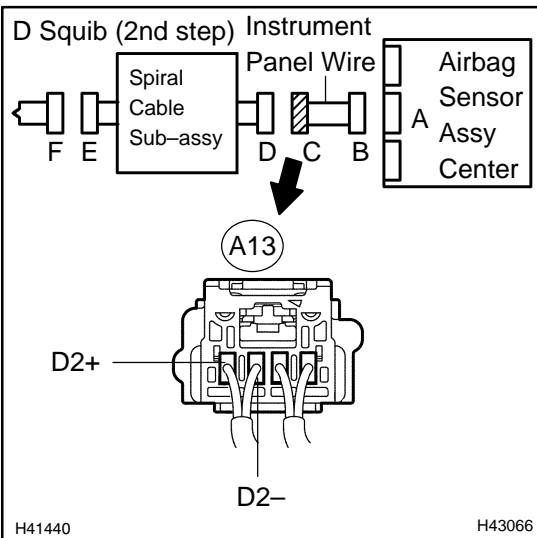

- (a) Disconnect the instrument panel wire connector from the spiral cable sub-assy.
- (b) Measure the resistance according to the value(s) in the table below.

Standard:

Tester connection (Connector "C")	Condition	Specified condition
A13-4 (D2+) - A13-3 (D2-)	Always	Below 1 Ω

NG → **REPAIR OR REPLACE INSTRUMENT PANEL WIRE**

OK

5 CHECK SPIRAL CABLE SUB-ASSY

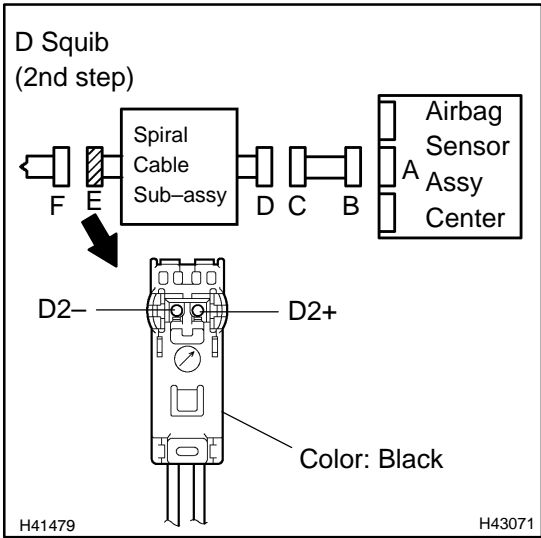

(a) Measure the resistance according to the value(s) in the table below.

Standard:

Tester connection (Connector "E")	Condition	Specified condition
D2+ - D2-	Always	Below 1 Ω

NG → **REPLACE SPIRAL CABLE SUB-ASSY**

OK

USE SIMULATION METHOD TO CHECK