

<b>DTC</b>	<b>P0136</b>	<b>OXYGEN SENSOR CIRCUIT MALFUNCTION (BANK 1 SENSOR 2)</b>
------------	--------------	--

## CIRCUIT DESCRIPTION

Refer to DTC P0130 on page [05-96](#).

DTC No	DTC Detection Condition	Trouble Area
P0136	The following condition (a) or (b) continues for 500 sec. or more: (a) During driving with the engine warmed up, heated oxygen sensor output does not change. (b) Heated oxygen sensor output is very low most of the time.	<ul style="list-style-type: none"> <li>• Open or short in heated oxygen sensor (bank 1 sensor 2) circuit</li> <li>• Heated oxygen sensor (bank 1 sensor 2)</li> <li>• Heated oxygen sensor heater (bank 1 sensor 2)</li> <li>• EFI relay</li> <li>• Air induction system</li> <li>• Fuel pressure</li> <li>• PCV hose connection</li> <li>• PCV valve and hose</li> <li>• Injector</li> <li>• Gas leakage in exhaust system</li> <li>• ECM</li> </ul>

### HINT:

Sensor 2 refers to the sensor farthest away from the engine assembly.

## MONITOR DESCRIPTION

The heated oxygen sensor generates waveform of a voltage between 0 V and 1 V in response to the oxygen concentration in the exhaust gases. When the output voltage of the heated oxygen sensor is 0.55 V or more, the ECM judges that the air-fuel ratio is RICH. When it is 0.40 V or less, the ECM judges that the air-fuel ratio is LEAN.

If the rear heated oxygen sensor output does not change between RICH and LEAN during "Stop and GO" driving, the ECM interprets this as malfunction in the sensor and sets a DTC. Also, if the sensor output remains at less than 0.05 V for more than 126 seconds (when ECM monitored the sensor for 210 seconds while the air-fuel feedback is being performed), the ECM will interpret this as a fault. In either case, the ECM will turn on the MIL and set a DTC.

## MONITOR STRATEGY

Related DTCs	P0136	Heated oxygen sensor output voltage (bank 1)
Required sensors/components	Main sensors	Heated rear oxygen sensor
	Related sensors	Mass air flow sensor, vehicle speed sensor
Frequency of operation	Once per drive cycles	
Duration	500 sec	
MIL operation	2 driving cycles	
Sequence of operation	None	

## TYPICAL ENABLING CONDITIONS

Item	Specification	
	Minimum	Maximum
The monitor will run whenever the following DTCs are not present	See "List of Disable a Monitor" table (On page <a href="#">05-24</a> )	
<b>Case 1:</b>		
Vehicle speed	2 mph (3 km/h)	–
Idle	OFF	
Fuel cut	OFF	
Time after fuel cut from ON to OFF	5 sec	–
Intake air amount per revolution	0.16 g/rev	–

Fuel system status	Closed – loop	
<b>Case 2 (Output voltage):</b>		
Time while the following conditions A and B are met	300 sec (Engine coolant temperature is less than 75°C (167°F)), 200 sec (Engine coolant temperature is 75°C (167°F) or more)	–
A. Fuel system status	Closed-loop	
B. Idle	OFF	
Deceleration count (The number of times accelerating and decelerating)	30 times	–
Deceleration is counted up when vehicle decelerates	3 mph (5 km/h) / 2 sec	–

## TYPICAL MALFUNCTION THRESHOLDS

Detection Criteria	Threshold
<b>Case 1:</b>	
Following conditions are met:	1, 2 and 3
1. Cumulative heated oxygen sensor monitor time	210 sec or more
2. Time while heated oxygen sensor voltage is less than 0.05V	126 sec or more
3. Maximum heated oxygen sensor rich time (0.45V or more)	Less than 20 sec
<b>Case 2:</b>	
Number of heated oxygen sensor voltage "switching"	0 times or less
"Switching" is counted when the sensor signal crosses the minimum or maximum voltage	
Minimum voltage	0.4 V or less
Maximum voltage	0.5 V or more

## COMPONENT OPERATING RANGE

Parameter	Standard Value
Heated oxygen sensor voltage	0 to 1 V

## MONITOR RESULT (MODE 06 DATA)

Test ID	Comp ID	Description of test data	Description of test limit	Unit	Conversion factor
\$03	–	Not supported by mode \$06, but by mode \$05	–	–	–

Refer to page [05-26](#) for detailed information on CHECKING MONITOR STATUS.

## WIRING DIAGRAM

Refer to DTC P0130 on page [05-96](#).

## INSPECTION PROCEDURE

HINT:

Hand-held tester only:

Narrowing down the trouble area is possible by performing the "SENSOR 1 (FRONT SENSOR)" ACTIVE TEST (heated oxygen sensor or other trouble areas can be distinguished).

(a) Perform ACTIVE TEST using the hand-held tester (A/F CONTROL).

HINT:

"A/F CONTROL" is ACTIVE TEST which changes the injection volume –12.5 % or +25 %.

- (1) Connect the hand-held tester to the DLC3 on the vehicle.
- (2) Turn the ignition switch ON.
- (3) Warm up the engine by running the engine at 2,500 rpm for approximately 3 minutes.

- (4) Select the item "DIAGNOSIS/ENHANCED OBD II/ACTIVE TEST/ A/F CONTROL".
- (5) Perform "A/F CONTROL" with the engine in an idle condition (press the right or left button).

**Result:**











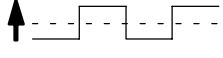

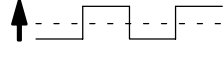
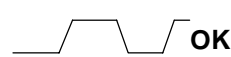
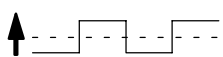
**Heated oxygen sensor reacts in accordance with increase and decrease of injection volume:**

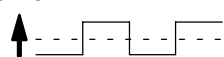
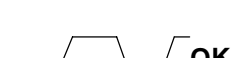
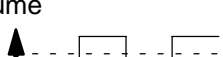
**+25 % → rich output: More than 0.5 V**

**-12.5 % → lean output: Less than 0.4 V**

**NOTICE:**

**There is a delay of few seconds in the sensor 1 (front sensor) output, and there is about 20 seconds delay at maximum in the sensor 2 (rear sensor).**

	Output voltage of heated oxygen sensor (sensor 1: front sensor)	Output voltage of heated oxygen sensor (sensor 2: rear sensor)	Mainly suspect trouble area
Case 1	Injection volume +25 % ↑  -12.5 % Output voltage More than 0.5 V  <b>OK</b> Less than 0.4V	Injection volume +25 % ↑  -12.5 % Output voltage More than 0.5 V  <b>OK</b> Less than 0.4V	—
Case 2	Injection volume +25 % ↑  -12.5 % Output voltage No reaction  <b>NG</b>	Injection volume +25 % ↑  -12.5 % Output voltage More than 0.5 V  <b>OK</b> Less than 0.4V	Sensor 1: front sensor (sensor 1, heater, sensor 1 circuit)
Case 3	Injection volume +25 % ↑  -12.5 % Output voltage More than 0.5 V  <b>OK</b> Less than 0.4V	Injection volume +25 % ↑  -12.5 % Output voltage No reaction  <b>NG</b>	Sensor 2: rear sensor (sensor 2, heater, sensor 2 circuit)
Case 4	Injection volume +25 % ↑  -12.5 % Output voltage No reaction  <b>NG</b>	Injection volume +25 % ↑  -12.5 % Output voltage No reaction  <b>NG</b>	Extremely rich or lean actual air-fuel ratio (Injector, fuel pressure, gas leakage in exhaust system, etc.)

The following A/F CONTROL procedure enables the technician to check and graph the voltage outputs of both the heated oxygen sensors.

For displaying the graph indication, enter "ACTIVE TEST / A/F CONTROL / USER DATA", then select "O2S B1S1 and O2S B1S2" by pressing "YES" button and push "ENTER" button before pressing "F4" button.

**HINT:**

- If different DTCs related to different systems that have terminal E2 as the ground terminal are output simultaneously, terminal E2 may be open.
- Read freeze frame data using the hand-held tester or the OBD II scan tool. Freeze frame data records the engine conditions when a malfunction is detected. When troubleshooting, it is useful for determining whether the vehicle was running or stopped, the engine was warmed up or not, the air-fuel ratio was lean or rich, etc. at the time of the malfunction.

**1 CHECK OTHER DTCS OUTPUT(IN ADDITION TO DTC P0136)**

- (a) Connect the hand-held tester or the OBD II scan tool to the DLC3.
- (b) Turn the ignition switch ON and push the hand-held tester or the OBD II scan tool main switch ON.
- (c) Select the item "DIAGNOSIS / OBD/MOBD / DTC INFO / CURRENT CODES".
- (d) Read the DTCS using the hand-held tester or the OBD II scan tool.

**Result:**

Display (DTC output)	Proceed to
Only "P0136" is output	A
"P0136" and other DTCS are output	B

**HINT:**

If any other codes besides "P0136" is output, perform the troubleshooting for those DTCS first.

**B** **GO TO RELEVANT DTC CHART**  
(See page 05-34)

**A**

**2 READ VALUE OF HAND-HELD TESTER OR OBD II SCAN TOOL(OUTPUT VOLTAGE OF HEATED OXYGEN SENSOR)**

- (a) Connect the hand-held tester or the OBD II scan tool to the DLC3.
- (b) Start the engine and push the hand-held tester or the OBD II scan tool main switch ON.
- (c) Select the item "DIAGNOSIS / ENHANCED OBD II / DATA LIST / ALL / O2S B1S1".
- (d) After warming up the engine, run the engine at 2,500 rpm for 3 minutes.
- (e) Read the output voltage of the heated oxygen sensor when the engine speed is suddenly increased.

**HINT:**

Quickly accelerate the engine to 4,000 rpm 3 times by using the accelerator pedal.

**Standard:**

**Heated oxygen sensor output voltage: Alternates from 0.4 V or less to 0.5 V or more.**

**OK** **Go to step 6**

**NG**

**3 INSPECT HEATED OXYGEN SENSOR(HEATER RESISTANCE)**

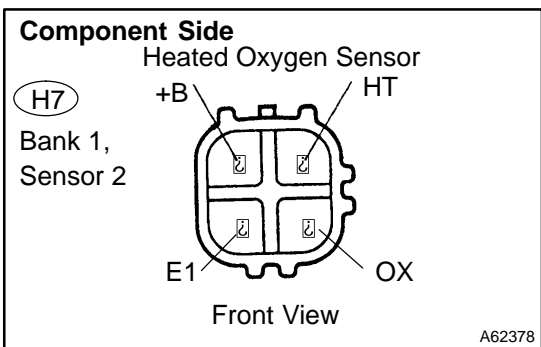

- (a) Disconnect the H7 heated oxygen sensor connector.
- (b) Measure the resistance between the terminals of the heated oxygen HT sensor connector.

**Standard:**

Tester Connection	Specified Condition
HT (H7-1) - +B (H7-2)	11 to 16 Ω at 20 °C (68 °F)
HT (H7-1) - E1 (H7-4)	10 kΩ or higher

- (c) Reconnect the heated oxygen sensor connector.

**NG** **REPLACE HEATED OXYGEN SENSOR**

**OK**

**4 INSPECT EFI RELAY**

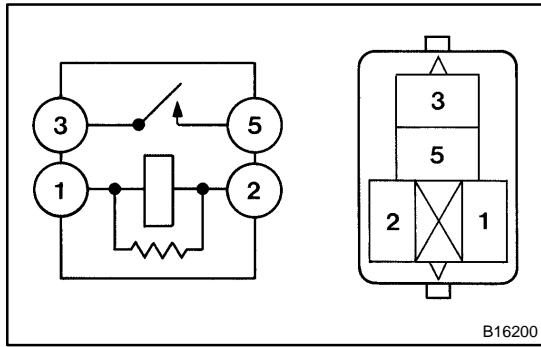

- (a) Remove the EFI relay from the engine room R/B.
- (b) Inspect the EFI relay.

**Standard:**

Tester Connection	Specified Condition
1 - 2	Continuity
3 - 5	No continuity
	Continuity (Apply battery voltage to terminals 1 and 2)

- (c) Reinstall the EFI relay.

**NG** → **REPLACE EFI RELAY**

**OK**

**5 CHECK HARNESS AND CONNECTOR(HEATED OXYGEN SENSOR - ECM)**

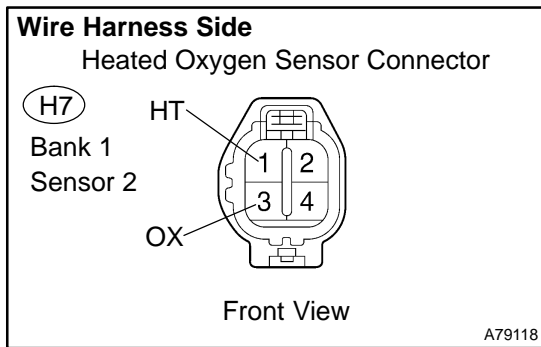

- (a) Disconnect the H7 heated oxygen sensor connector.
- (b) Disconnect the E4 and E6 ECM connectors.
- (c) Measure the resistance between the wire harness side connectors.

**Standard (Check for open):**

Tester Connection	Specified Condition
HT (H7-1) - HTL2 (E4-4)	Below 1 Ω
OX (H7-3) - OXL2 (E6-21)	

**Standard (Check for short):**

Tester Connection	Specified Condition
HT (H7-1) or HTL2 (E4-4) - Body ground	10 kΩ or higher
OX (H7-3) or OXL2 (E6-21) - Body ground	

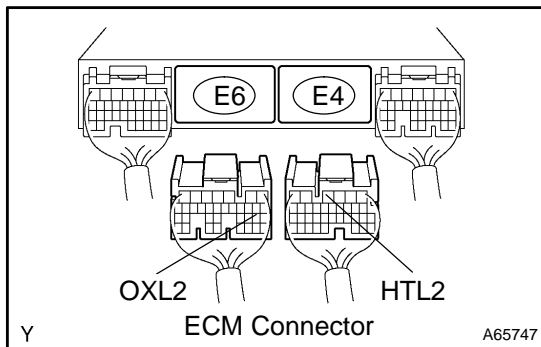

- (d) Reconnect the heated oxygen sensor connector.
- (e) Reconnect the ECM connector.

**Reference (Bank 1 Sensor 2 System Drawing)**

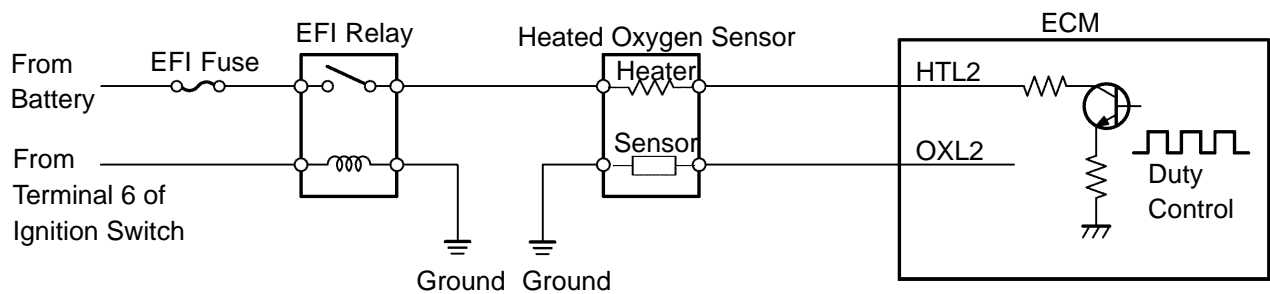

NG

REPAIR OR REPLACE HARNESS OR CONNECTOR

OK

REPLACE HEATED OXYGEN SENSOR

6 PERFORM CONFIRMATION DRIVING PATTERN(See page 05-96)

HINT:

Clear all DTCs prior to performing the confirmation driving pattern.

GO

7 READ OUTPUT DTC(DTC P0136 IS OUTPUT AGAIN)

- (a) Connect the hand-held tester or the OBD II scan tool to the DLC3.
- (b) Turn the ignition switch ON and push the hand-held tester or the OBD II scan tool main switch ON.
- (c) Select the item "DIAGNOSIS / OBD/MOBD / DTC INFO / CURRENT CODES".
- (d) Read the DTCs using the hand-held tester or the OBD II scan tool.

**Result:**

Display (DTC output)	Proceed to
"P0136" is output again	A
"P0136" is not output again	B

B

CHECK FOR INTERMITTENT PROBLEMS  
(See page 05-41)

A

REPLACE HEATED OXYGEN SENSOR