

DTC	P0031	OXYGEN SENSOR HEATER CONTROL CIRCUIT LOW (BANK 1 SENSOR 1)
DTC	P0032	OXYGEN SENSOR HEATER CONTROL CIRCUIT HIGH (BANK 1 SENSOR 1)
DTC	P0037	OXYGEN SENSOR HEATER CONTROL CIRCUIT LOW (BANK 1 SENSOR 2)
DTC	P0038	OXYGEN SENSOR HEATER CONTROL CIRCUIT HIGH (BANK 1 SENSOR 2)

CIRCUIT DESCRIPTION

Refer to DTC P0130 on page 05-96.

HINT:

The ECM provides a pulse width modulated control circuit to adjust current through the heater. The heated oxygen sensor heater circuit uses a relay on the B+ side of the circuit.

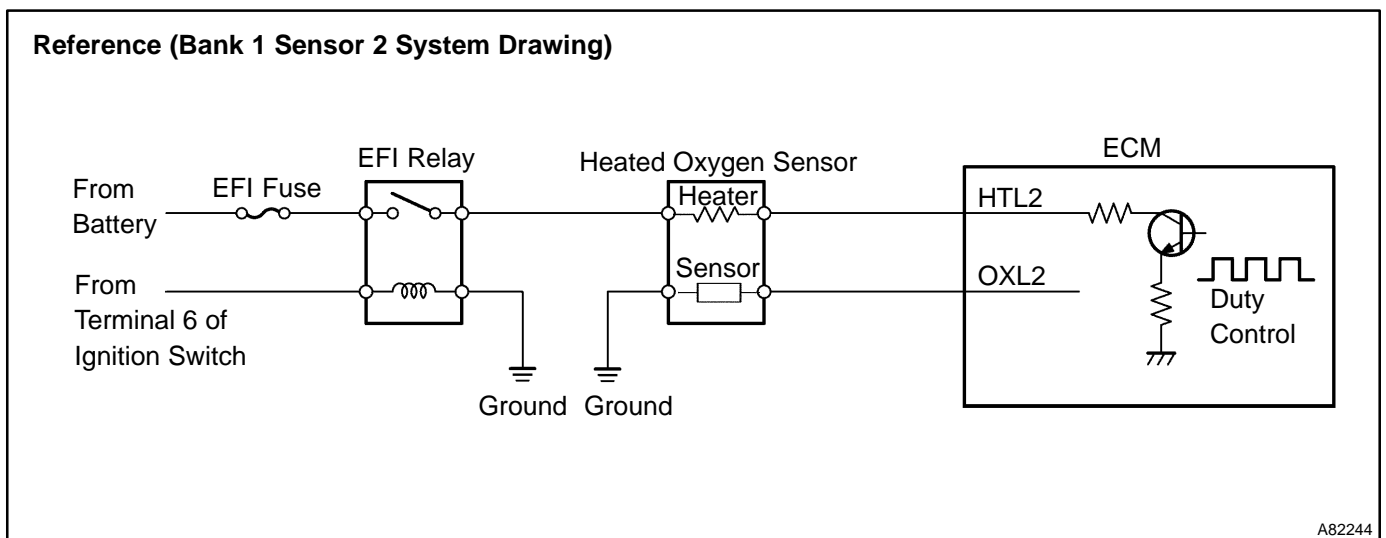
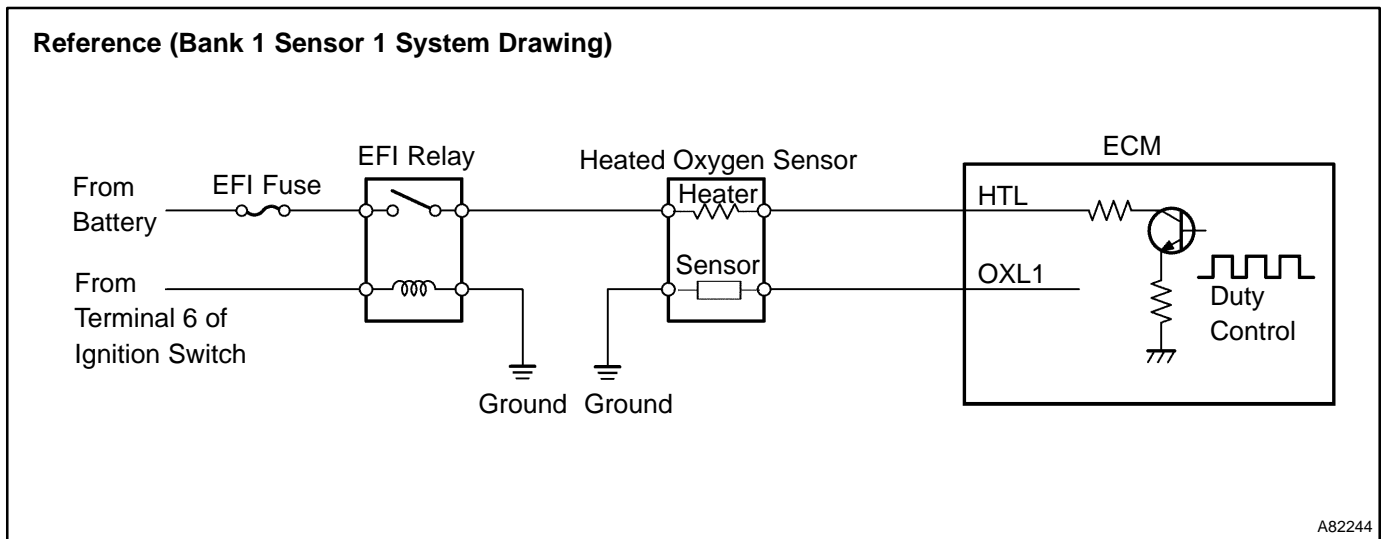

DTC No.	DTC Detection Condition	Trouble Area
P0031 P0037	Heater current is 0.25 A or less when heater operates with +B greater than 11.5 V (1 trip detection logic)	<ul style="list-style-type: none"> • Open or short in heater circuit of heated oxygen sensor • Heated oxygen sensor heater
P0032 P0038	Heater current exceeds 2 A when the heater operates. (1 trip detection logic)	<ul style="list-style-type: none"> • EFI relay • ECM

MONITOR DESCRIPTION

The ECM uses the oxygen sensor information to regulate the air–fuel ratio close to a stoichiometric ratio. This maximizes the catalytic converter's ability to purify the exhaust gases. The sensor detects oxygen levels in the exhaust gas and sends this signal to the ECM.

The inner surface of the sensor element is exposed to outside air. The outer surface of the sensor element is exposed to exhaust gas. The sensor element is made of platinum coated zirconia and includes an integrated heating element. The oxygen sensor has the characteristic whereby its output voltage changes suddenly in the vicinity of the stoichiometric air–fuel ratio. When heated, the sensor becomes very efficient. If the temperature of the exhaust is low, the sensor will not generate useful voltage signals without supplemental heating. The ECM regulates the supplemental heating using a duty–cycle approach to regulate the average current in the heater element. If the heater current is out of the normal range, the sensor's output signals will be inaccurate and the ECM cannot regulate the air–fuel ratio properly. When the heater current is out of the normal operating range, the ECM interprets this as a malfunction and sets a DTC.

Example:

The ECM will set a high current DTC if the current in the sensor is more than 2 A when the heater is OFF. Similarly, the ECM will set a low current DTC if the current is less than 0.25 A when the heater is ON.

MONITOR STRATEGY

Related DTCs	P0031	Heated oxygen sensor heater current bank 1 sensor 1 (low current)
	P0032	Heated oxygen sensor heater current bank 1 sensor 1 (high current)
	P0037	Heated oxygen sensor heater current bank 1 sensor 2 (low current)
	P0038	Heated oxygen sensor heater current bank 1 sensor 2 (high current)
Required sensors/components	Main sensors	Heated oxygen sensor
	Related sensors	Vehicle speed sensor
Frequency of operation	Continuous	
Duration	0.3 sec	
MIL operation	1 driving cycle	
Sequence of operation	None	

TYPICAL ENABLING CONDITIONS

Item	Specification	
	Minimum	Maximum
The monitor will run whenever the following DTCs are not present	See "List of Disable a Monitor" table (On page 05-24)	
P0032, P0038 (High current):		
Intrusive harging is OFF		
P0031, P0037 (Low current):		
Either following condition is met:	A or B	
A. Following conditions are met:	1, 2, 3, 4 and 5	
1. Time after engine start	250 sec	500 sec
2. Battery voltage	10.5 V	16 V
3. Vehicle speed	–	56 mph (90 km/h)
4. Misfire	No detect	

5. Pass/Fail detection in this driving cycle	No detect	
B. Following conditions are met:	1, 2, 3, 4 and 5	
1. Time after engine start	500 sec	–
2. Battery voltage	10.5 V	16 V
3. Vehicle speed	25 mph (40 km/h)	–
4. Misfire	None detected	
5. Pass/Fail detection in this driving cycle	Pass and fail detection has not occurred yet	

TYPICAL MALFUNCTION THRESHOLDS

Detection Criteria	Threshold
P0032, P0038 (High current):	
Heated oxygen sensor heater current	More than 2 A (while supplemental heating is off)
P0031, P0037 (Low current):	
Heated oxygen sensor heater current	Less than 0.25 A (at 0.3 sec after heater "ON")

COMPONENT OPERATING RANGE

Parameter	Standard Value
Heated oxygen sensor heater current under the following conditions: (a) Engine has been warmed up (b) Engine is in an idle (c) Battery voltage is 11 to 14V	0.4 to 1.0 A

MONITOR RESULT (MODE 06 DATA)

Test ID	Comp ID	Description of test data	Description of test limit	Unit	Conversion factor
\$04	\$81 to \$82	Maximum heated oxygen sensor heater current	Maximum threshold heater current to detect heated oxygen sensor heater circuit malfunction	A	Multiply by 0.000076

Refer to page [05-26](#) for detailed information on CHECKING MONITOR STATUS.

WIRING DIAGRAM

Refer to DTC P0130 on page [05-96](#).

INSPECTION PROCEDURE

HINT:

- If different DTCs related to different systems that have terminal E2 as the ground terminal are output simultaneously, terminal E2 may be open.
- Read freeze frame data using the hand-held tester or the OBD II scan tool. Freeze frame data records the engine conditions when a malfunction is detected. When troubleshooting, it is useful for determining whether the vehicle was running or stopped, the engine was warmed up or not, the air-fuel ratio was lean or rich, etc. at the time of the malfunction.

1 INSPECT HEATED OXYGEN SENSOR(HEATER RESISTANCE)

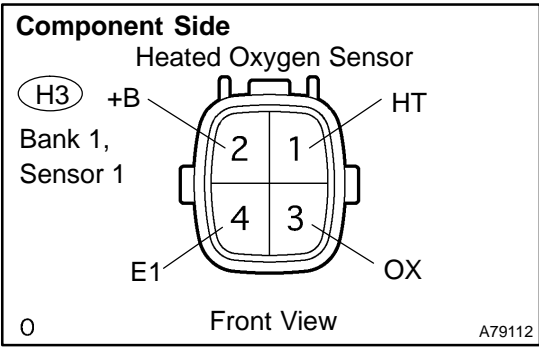

- (a) Disconnect the H3 or H7 heated oxygen sensor connector.
- (b) Measure the resistance between the terminals of the heated oxygen sensor connector.

Standard: (Bank 1, Sensor 1)

Tester Connection	Specified Condition
HT (H3-1) – +B (H3-2)	11 to 16 Ω at 20 °C (68 °F)
HT (H3-1) – E1 (H3-4)	10 kΩ or higher

Standard: (Bank 1, Sensor 2)

Tester Connection	Specified Condition
HT (H7-1) – +B (H7-2)	11 to 16 Ω at 20 °C (68 °F)
HT (H7-1) – E1 (H7-4)	10 kΩ or higher

- (c) Reconnect the heated oxygen sensor connector.

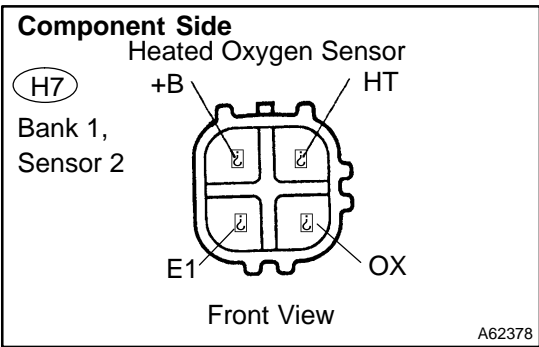

NG REPLACE HEATED OXYGEN SENSOR

OK

2 INSPECT EFI RELAY

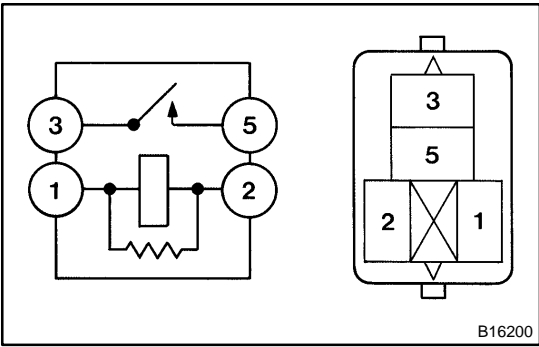

- (a) Remove the EFI relay from the engine room R/B.
- (b) Inspect the EFI relay.

Standard:

Tester Connection	Specified Condition
1 – 2	Below 1 Ω
3 – 5	10 kΩ or higher
	Below 1 Ω (Apply battery voltage to terminals 1 and 2)

- (c) Reinstall the EFI relay.

NG REPLACE EFI RELAY

OK

3 INSPECT ECM(HTL OR HTL2 VOLTAGE)

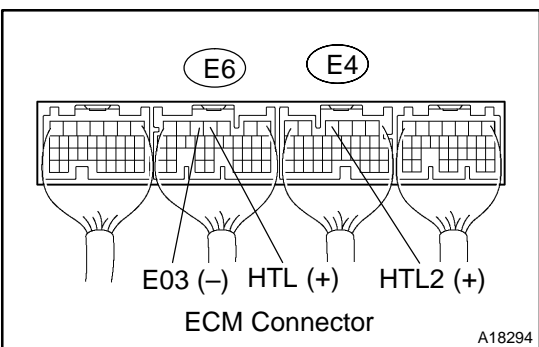

- (a) Turn the ignition switch ON.
- (b) Measure the voltage between the applicable terminals of the E4 and E6 ECM connectors.

Standard: (Bank 1, Sensor 1)

Tester Connection	Specified Condition
HTL (E6-4) – E03 (E6-5)	9 to 14 V

Standard: (Bank 1, Sensor 2)

Tester Connection	Specified Condition
HTL2 (E4-4) – E03 (E6-5)	9 to 14 V

OK REPLACE ECM (See page 10-17)

NG

4 CHECK HARNESS AND CONNECTOR(HEATED OXYGEN SENSOR - ECM, HEATED OXYGEN SENSOR - EFI RELAY)

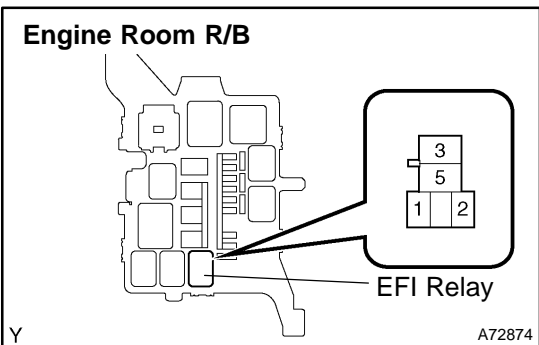
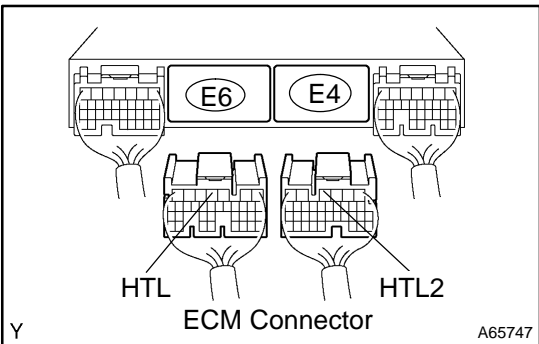
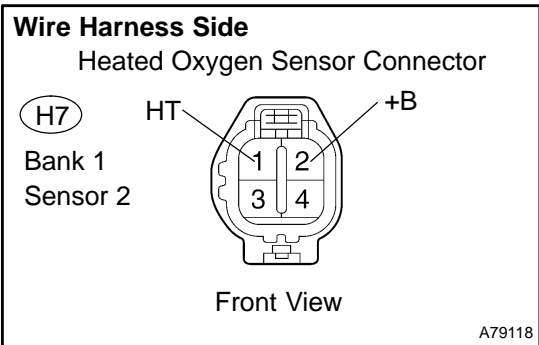
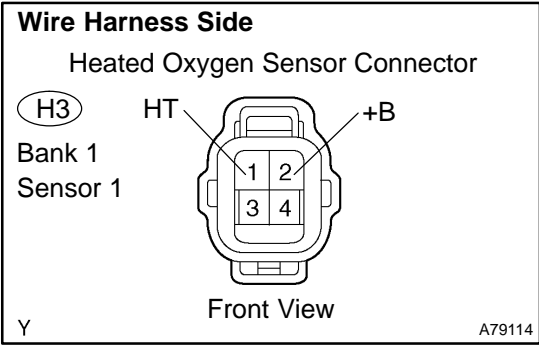

- (a) Check the harness and connector between the ECM and heated oxygen sensor connectors.
- (1) Disconnect the H3 or H7 heated oxygen sensor connector.
 - (2) Disconnect the E4 and E6 ECM connectors.
 - (3) Measure the resistance between the wire harness side connectors.

Standard (Check for open): (Bank 1, Sensor 1)

Tester Connection	Specified Condition
HT (H3-1) - HTL (E6-4)	Below 1 Ω

Standard (Check for short): (Bank 1, Sensor 1)

Tester Connection	Specified Condition
HT (H3-1) or HTL (E6-4) - Body ground	10 kΩ or higher

Standard (Check for open): (Bank 1, Sensor 2)

Tester Connection	Specified Condition
HT (H7-1) - HTL2 (E4-4)	Below 1 Ω

Standard (Check for short): (Bank 1, Sensor 2)

Tester Connection	Specified Condition
HT (H7-1) or HTL2 (E4-4) - Body ground	10 kΩ or higher

- (4) Reconnect the heated oxygen sensor connector.
 - (5) Reconnect the ECM connector.
- (b) Check the harness and connector between the heated oxygen sensor connector and EFI relay.
- (1) Disconnect the H3 or H7 heated oxygen sensor connector.
 - (2) Remove the EFI relay from the engine room R/B.
 - (3) Measure the resistance between the wire harness side connectors.

Standard (Check for open): (Bank 1, Sensor 1)

Tester Connection	Specified Condition
+B (H3-2) - EFI relay (3)	Below 1 Ω

Standard (Check for short): (Bank 1, Sensor 1)

Tester Connection	Specified Condition
+B (H3-2) or EFI relay (3) - Body ground	10 kΩ or higher

Standard (Check for open): (Bank 1, Sensor 2)

Tester Connection	Specified Condition
+B (H7-2) - EFI relay (3)	Below 1 Ω

Standard (Check for short): (Bank 1, Sensor 2)

Tester Connection	Specified Condition
+B (H7-2) or EFI relay (3) - Body ground	10 kΩ or higher

- (4) Reconnect the heated oxygen sensor connector.

(5) Reinstall the EFI relay.

NG	REPAIR	OR	REPLACE	HARNESS	OR
	CONNECTOR				

OK

REPLACE ECM (See page [10-17](#))