

DTC	P0100	MASS OR VOLUME AIR FLOW CIRCUIT
DTC	P0102	MASS OR VOLUME AIR FLOW CIRCUIT LOW INPUT
DTC	P0103	MASS OR VOLUME AIR FLOW CIRCUIT HIGH INPUT

CIRCUIT DESCRIPTION

The MAF (Mass Air Flow) sensor measures the amount of air flowing through the throttle valve. The ECM uses this information to determine the fuel injection time and provide a proper air-fuel ratio. Inside the MAF sensor, there is a heated platinum wire exposed to the flow of intake air.

By applying a specific current to the wire, the ECM heats this wire to a given temperature. The flow of incoming air cools the wire and an internal thermister, changing their resistance. To maintain a constant current value, the ECM varies the voltage applied to these components in the MAF sensor. The voltage level is proportional to the airflow through the sensor and the ECM interprets this voltage as the intake air amount. The circuit is constructed so that the platinum hot wire and temperature sensor provide a bridge circuit, with the power transistor controlled so that the potential of A and B remains equal to maintain the set temperature.

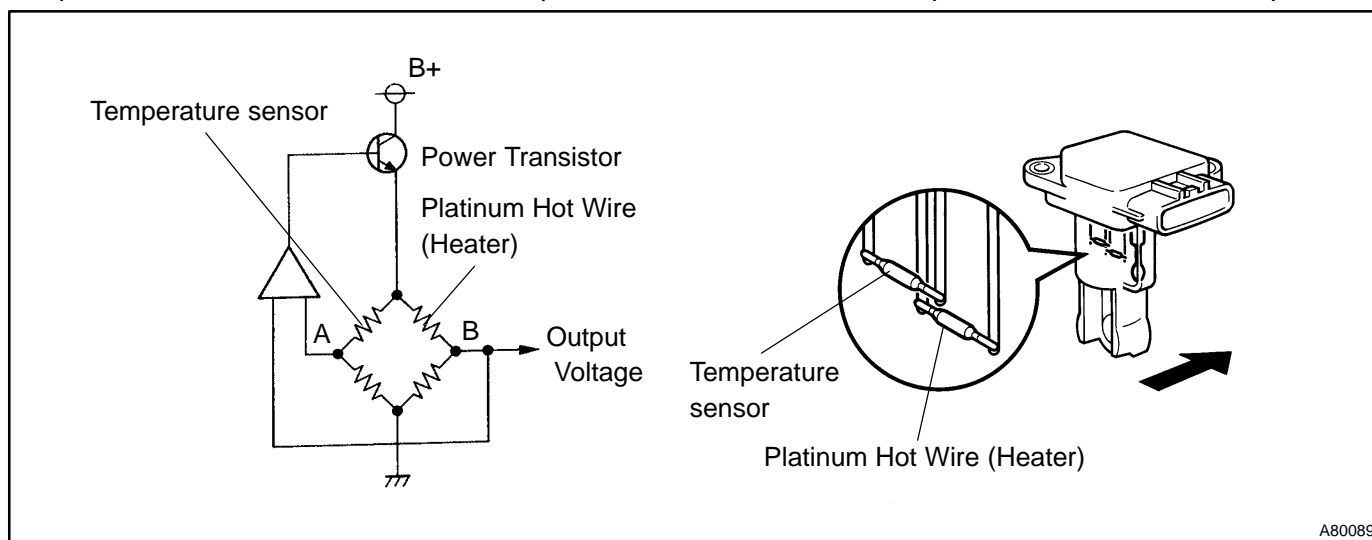

A80089

DTC No.	DTC Detection Condition	Trouble Area
P0100	When the mass air flow sensor circuit has an open or a short for more than 3 sec. under the 4,000 rpm engine speed.	<ul style="list-style-type: none"> • Open or short in mass air flow sensor circuit • Mass air flow sensor • ECM
P0102	When the mass air flow sensor circuit has an open for more than 3 sec. under the 4,000 rpm engine speed.	
P0103	When the mass air flow sensor circuit has a short for more than 3 sec. under the 4,000 rpm engine speed.	

HINT:

After confirming DTC "P0100, P0102 or P0103", use the hand-held tester or the OBD II scan tool to confirm the mass air flow ratio from the "DIAGNOSIS / ENHANCED OBD II / DATA LIST / ALL".

Air Flow Value (gm/s)	Malfunction
Approx. 0.0	<ul style="list-style-type: none"> • Mass air flow sensor power source circuit open • VG circuit open or short
271.0 or more	<ul style="list-style-type: none"> • E2G circuit open

MONITOR DESCRIPTION

If there is a defect in the sensor or an open or short circuit, the voltage level will deviate outside the normal operating range. The ECM interprets this deviation as a defect in the MAF sensor and sets a DTC.

Example:

When the sensor voltage output is less than 0.2 V or more than 4.9 V and if either condition continues more than 3 sec.

MONITOR STRATEGY

Related DTCs	P0100	Mass air flow sensor circuit range check (fluttering)
	P0102	Mass air flow sensor circuit range check (low voltage)
	P0103	Mass air flow sensor circuit range check (high voltage)
Required sensors/components	Mass air flow sensor	
Frequency of operation	Continuous	
Duration	3 sec	
MIL operation	Immediately (when engine speed at less than 4,000rpm) 2 driving cycles (when engine speed at 4,000 rpm or more)	
Sequence of operation	None	

TYPICAL ENABLING CONDITIONS

The monitor will run whenever the following DTCs are not present	See "List of Disable a Monitor" table (On page 05-24)
--	---

TYPICAL MALFUNCTION THRESHOLDS

Detection Criteria	Threshold
P0100:	
Mass air flow sensor voltage	Less than 0.2 V or more than 4.9 V
P0102:	
Mass air flow sensor voltage	Less than 0.2 V
P0103:	
Mass air flow sensor voltage	More than 4.9 V

COMPONENT OPERATING RANGE

Parameter	Standard Value
Mass air flow sensor voltage	0.4 to 2.2 V

WIRING DIAGRAM

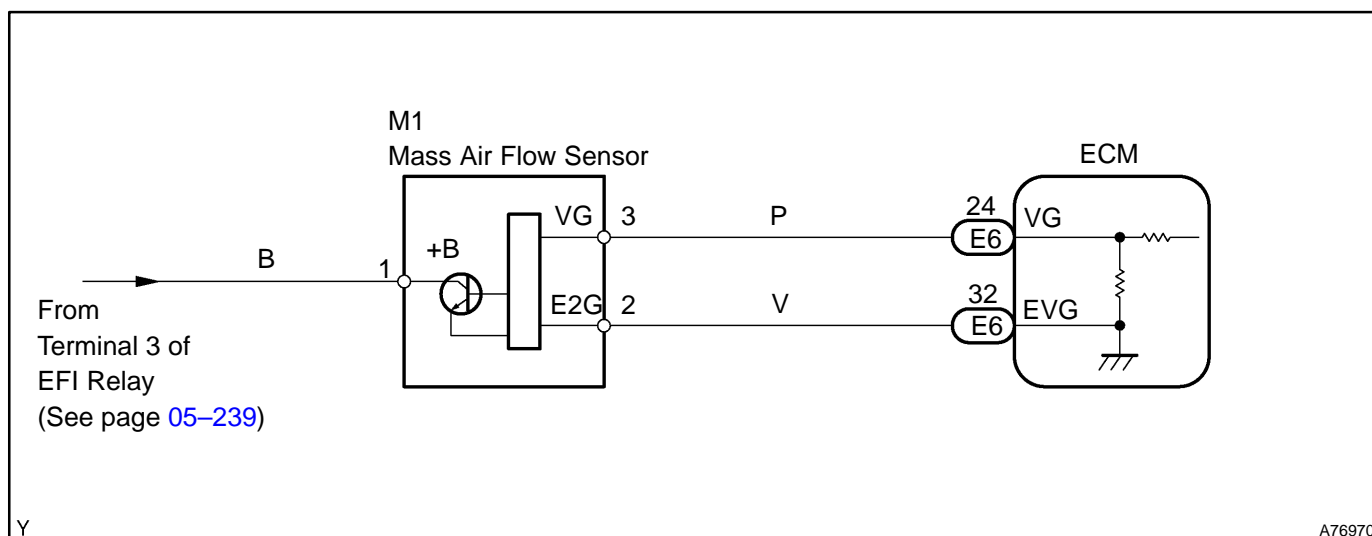

INSPECTION PROCEDURE

HINT:

Read freeze frame data using the hand-held tester or the OBD II scan tool. Freeze frame data records the engine conditions when a malfunction is detected. When troubleshooting, it is useful for determining whether the vehicle was running or stopped, the engine was warmed up or not, the air-fuel ratio was lean or rich, etc. at the time of the malfunction.

1	READ VALUE OF HAND-HELD TESTER OR OBD II SCAN TOOL(MASS AIR FLOW RATE)
----------	---

- (a) Connect the hand-held tester or the OBD II scan tool to the DLC3.
- (b) Start the engine.
- (c) Push the hand-held tester or the OBD II scan tool main switch ON.
- (d) Select the item "DIAGNOSIS / ENHANCED OBD II / DATA LIST / ALL / MAF" and read its value displayed on the hand-held tester or the OBD II scan tool.

Result:

Air Flow Rate (gm/s)	Proceed to
0.0	A
271.0 or more	B
Between 1.0 and 270.0 (*1)	C

*1: The value must be changed when the throttle valve is opened or closed.

B → **Go to step 6**

C → **CHECK FOR INTERMITTENT PROBLEMS (See page 05-41)**

A

2	INSPECT MASS AIR FLOW SENSOR(POWER SOURCE)
----------	---

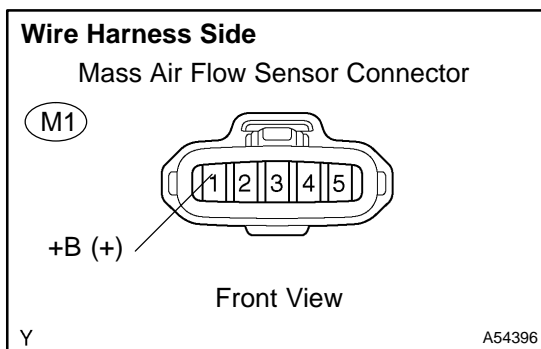

- (a) Turn the ignition switch ON.
- (b) Disconnect the M1 mass air flow sensor connector.
- (c) Measure the voltage between the terminal of the wire harness side connector and body ground.

Standard:

Tester Connection	Specified Condition
+B (M1-1) - Body ground	9 to 14 V

- (d) Reconnect the mass air flow sensor connector.

NG → **Go to step 5**

OK

3 INSPECT ECM(VG VOLTAGE)

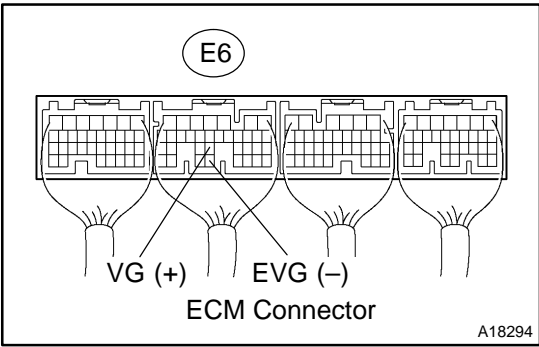

- (a) Start the engine.
- (b) Measure the voltage between the terminals of the E6 ECM connector.

HINT:
The shift position should be P or N and the A/C switch should be turned OFF.

Standard:

Tester Connection	Condition	Specified Condition
VG (E6-24) – EVG (E6-32)	Engine is idling	0.5 to 3.0 V

OK → **REPLACE ECM (See page 10-17)**

NG

4 CHECK HARNESS AND CONNECTOR(MASS AIR FLOW SENSOR – ECM)

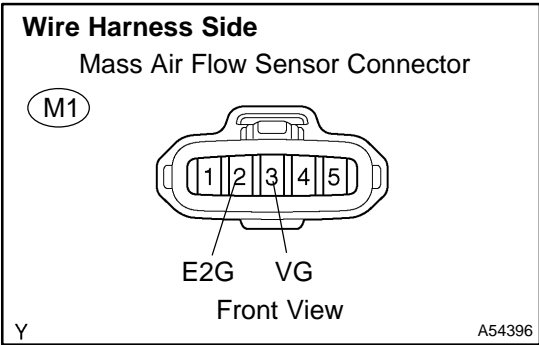

- (a) Disconnect the M1 mass air flow sensor connector.
- (b) Disconnect the E6 ECM connector.
- (c) Measure the resistance between the wire harness side connectors.

Standard (Check for open):

Tester Connection	Specified Condition
VG (M1-3) – VG (E6-24)	Below 1 Ω
E2G (M1-2) – EVG (E6-32)	

Standard (Check for short):

Tester Connection	Specified Condition
VG (M1-3) or VG (E6-24) – Body ground	10 kΩ or higher

- (d) Reconnect the mass air flow sensor connector.
- (e) Reconnect the ECM connector.

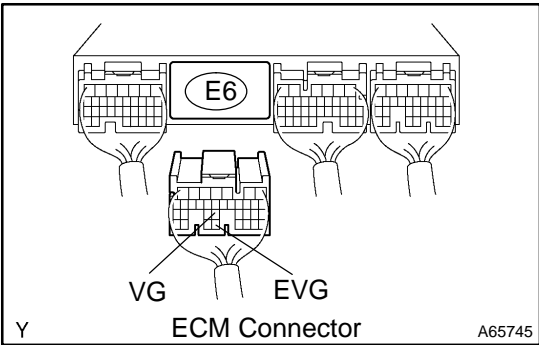

NG → **REPAIR OR REPLACE HARNESS OR CONNECTOR**

OK

REPLACE MASS AIR FLOW SENSOR

5 CHECK HARNESS AND CONNECTOR(MASS AIR FLOW SENSOR - EFI RELAY)

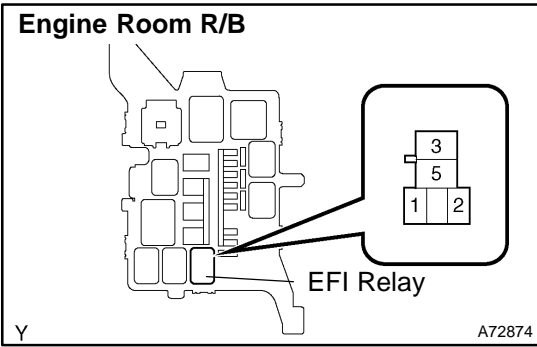

- (a) Remove the EFI relay from the engine room R/B.
- (b) Disconnect the M1 mass air flow sensor connector.
- (c) Measure the resistance between the wire harness side connectors.

Standard (Check for open):

Tester Connection	Specified Condition
+B (M1-1) - EFI relay (3)	Below 1 Ω

Standard (Check for short):

Tester Connection	Specified Condition
+B (M1-1) or EFI relay (3) - Body ground	10 kΩ or higher

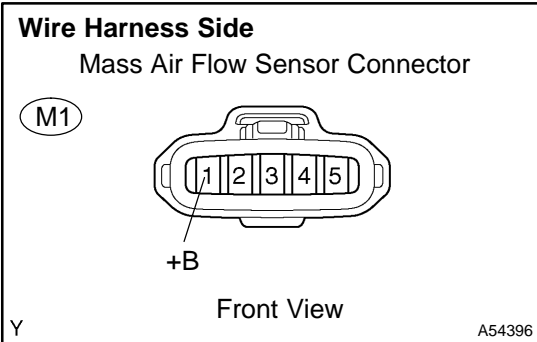

- (d) Reconnect the mass air flow sensor connector.
- (e) Reinstall the EFI relay.

NG → **REPAIR OR REPLACE HARNESS OR CONNECTOR**

OK

CHECK FOR ECM POWER SOURCE CIRCUIT (See page 05-239)

6 INSPECT ECM(SENSOR GROUND)

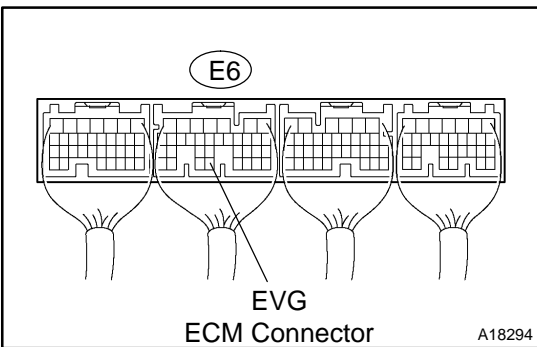

- (a) Measure the resistance between the specified terminals of the E6 ECM connector.

Standard:

Tester Connection	Specified Condition
EVG (E6-32) - Body ground	Below 1 Ω

NG → **REPLACE ECM (See page 10-17)**

OK

7 CHECK HARNESS AND CONNECTOR(MASS AIR FLOW SENSOR - ECM)

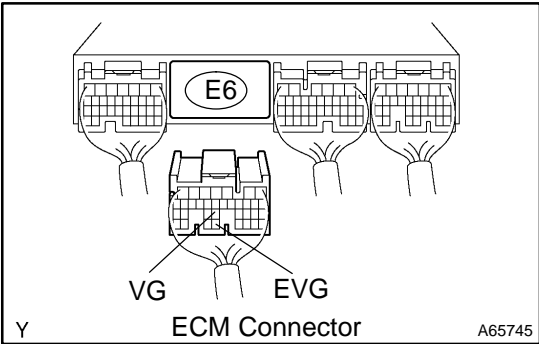
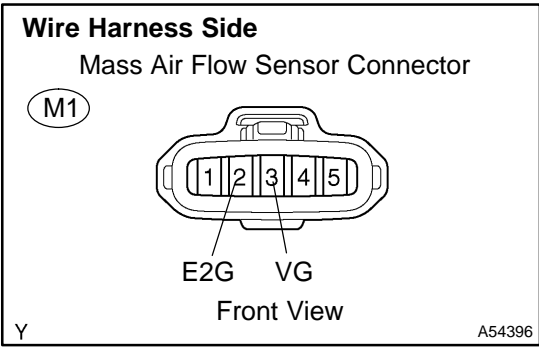

- (a) Disconnect the M1 mass air flow sensor connector.
- (b) Disconnect the E6 ECM connector.
- (c) Measure the resistance between the wire harness side connectors.

Standard (Check for open):

Tester Connection	Specified Condition
VG (M1-3) - VG (E6-24)	Below 1 Ω
E2G (M1-2) - EVG (E6-32)	

Standard (Check for short):

Tester Connection	Specified Condition
VG (M1-3) or VG (E6-24) - Body ground	10 kΩ or higher

- (d) Reconnect the mass air flow sensor connector.
- (e) Reconnect the ECM connector.

NG → **REPAIR OR REPLACE HARNESS OR CONNECTOR**

OK

REPLACE MASS AIR FLOW SENSOR