

DTC	P0325	KNOCK SENSOR 1 CIRCUIT (BANK 1 OR SINGLE SENSOR)
------------	--------------	---

CIRCUIT DESCRIPTION

Knock sensor is fitted on the cylinder block to detect the engine knocking. This sensor contains a piezoelectric element which generates a voltage when it becomes deformed, which occurs when the cylinder block vibrates due to knocking. If engine knocking occurs, the ignition timing is delayed to suppress it.

DTC No.	DTC Detecting Condition	Trouble Area
P0325	Knock sensor signal level remain low more than 10 seconds	<ul style="list-style-type: none"> • Open or short in knock sensor circuit • Knock sensor (under-torqued or loose) • ECM

HINT:

If the ECM detects the DTC "P0325", it enters the fail-safe mode in which the corrective retarded angle value is set to the maximum value.

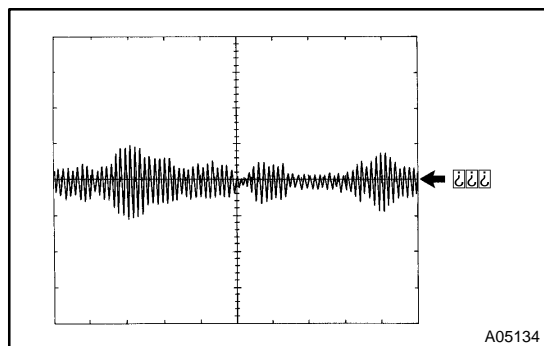

Reference: Inspection using the oscilloscope.

HINT:

The correct waveform is as shown on the left.

Item	Details
Terminal	KNK1 - E1
Equipment Settings	0.01 to 10 V/Division, 0.01 to 10 msec./Division
Condition	After warming up the engine, keep the engine speed at 4,000 rpm.

MONITOR DESCRIPTION

The knock sensor, detects spark knock. When spark knock occurs, the sensor picks-up vibrates in a specific frequency range. When the ECM detects voltage in this frequency range, it retards the ignition timing to suppress the spark knock.

The ECM also senses background engine noise with the knock sensor and uses this noise to check for faults in the sensor. If the knock sensor signal level is too low for more than 10 seconds, and if the knock sensor output voltage is out of normal range, the ECM interprets this as a fault in the knock sensor and sets a DTC.

MONITOR STRATEGY

Related DTCs	P0325	Knock sensor (bank 1) range check or rationality
Required sensors/components	Main sensors	Knock sensor
	Related sensors	Crankshaft position sensor, camshaft position sensor, engine coolant temperature sensor, mass air flow sensor
Frequency of operation	Continuous	
Duration	10 sec	
MIL operation	Immediately	
Sequence of operation	None	

TYPICAL ENABLING CONDITIONS

Item	Specification	
	Minimum	Maximum
The monitor will run whenever the following DTCs are not present	See "List of Disable a Monitor" table (On page 05-24)	
(Range check/Rationality):		
Battery voltage	10 V	-
Idle	OFF	
Time after engine start	5 sec	-
Engine coolant temperature	60°C (140°F)	-
Intake air amount per revolution	0.35 g/rev	-

TYPICAL MALFUNCTION THRESHOLDS

Detection criteria	Threshold
Knock sensor's voltage output remains at a low level for a specific period of time	10 sec

WIRING DIAGRAM

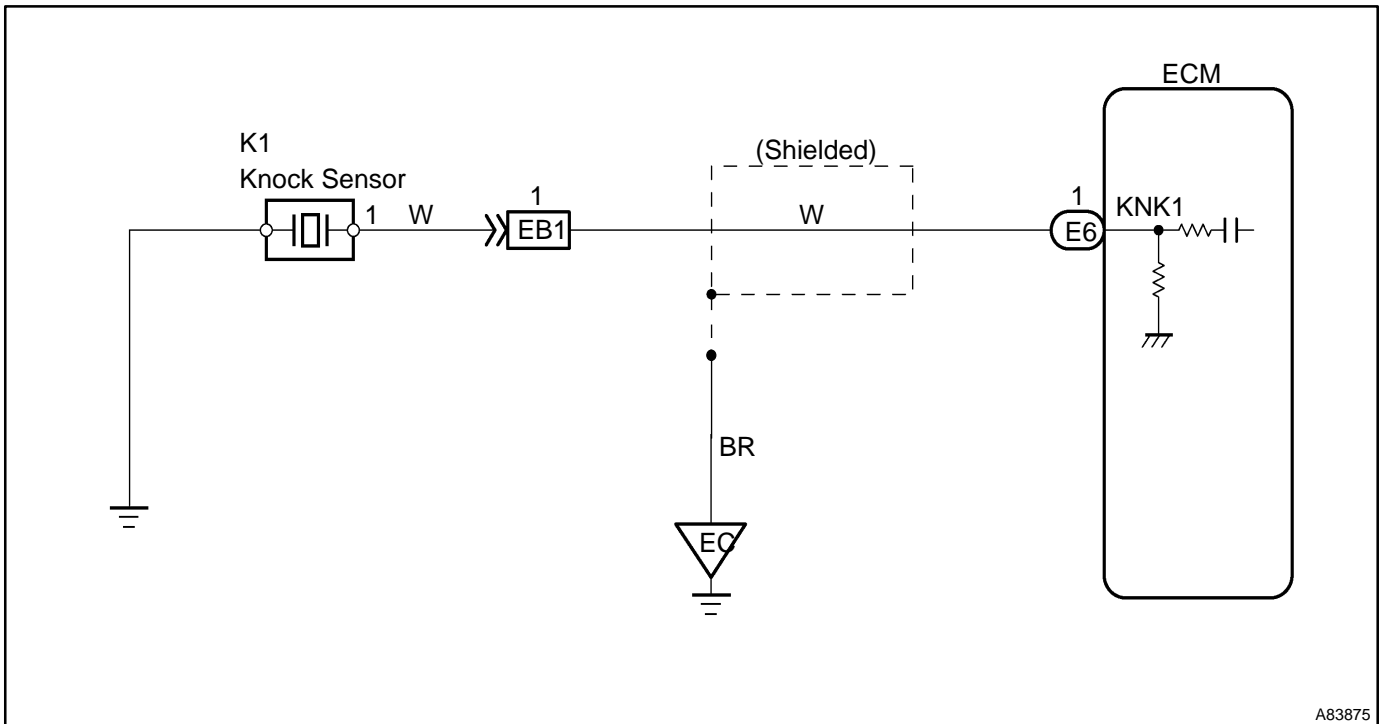

A83875

INSPECTION PROCEDURE

HINT:

Read freeze frame data using the hand-held tester or the OBD II scan tool. Freeze frame data records the engine conditions when a malfunction is detected. When troubleshooting, it is useful for determining whether the vehicle was running or stopped, the engine was warmed up or not, the air-fuel ratio was lean or rich, etc. at the time of the malfunction.

1 CHECK HARNESS AND CONNECTOR

- (a) Disconnect the K1 knock sensor connector.
- (b) Check for short between the knock sensor connector and the body ground.

Resistance: 1 MΩ or more

- (c) Reconnect the knock sensor connector.

OK → Go to step 3

NG

2 INSPECT KNOCK SENSOR (See page 10-2)

NG → REPLACE KNOCK SENSOR

OK

3 CHECK HARNESS AND CONNECTOR(ECM – KNOCK SENSOR)

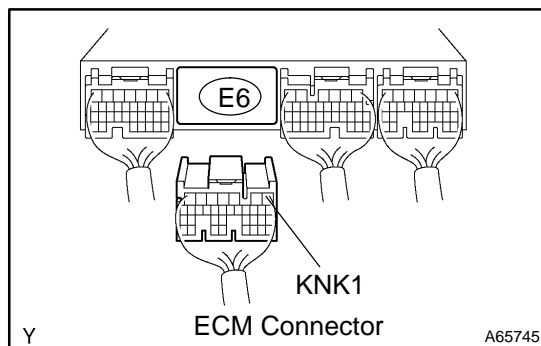

- (a) Disconnect the K1 knock sensor connector.
- (b) Disconnect the E6 ECM connector.
- (c) Measure the resistance between the wire harness side connectors.

Standard (Check for open):

Tester Connection	Specified Condition
Knock sensor (K1-1) – KNK1 (E6-1)	Below 1 Ω

Standard (Check for short):

Tester Connection	Specified Condition
Knock sensor (K1-1) or KNK1 (E6-1) – Body ground	10 kΩ or higher

- (d) Reconnect the knock sensor connector.
- (e) Reconnect the ECM connector.

NG → REPAIR OR REPLACE HARNESS OR CONNECTOR

OK

4	CONFIRM THE MALFUNCTION DISAPPEAR WHEN A GOOD KNOCK SENSOR IS INSTALLED
----------	--

SST 09816-30010

- (a) Replace the knock sensor with a new one.
 - (1) Remove the knock sensor.
 - (2) Install a new knock sensor.
- Torque: 44 N·m (450 kgf·cm, 32.6 ft·lbf)**
- (b) Perform the driving test.
 - (c) Connect the hand-held tester or the OBD II scan tool to the DLC3.
 - (d) Turn the ignition switch ON and push the hand-held tester or the OBD II scan tool main switch ON.
 - (e) Select the item "DIAGNOSIS / OBD/MOBD / DTC INFO / CURRENT CODES".
 - (f) Read the DTC using the hand-held tester or the OBD II scan tool.

Result:

Display (DTC output)	Proceed to
"P0325" is output	A
"P0325" is not output	B

B ▶ **REPLACE KNOCK SENSOR**

A

REPLACE ECM (See page 10-17)