

# FUEL PUMP CONTROL CIRCUIT

## CIRCUIT DESCRIPTION

In the diagram below, when the engine is cranked, current flows from terminal ST2 of the ignition switch to the starter relay coil and also current flows to terminal STA of the ECM (STA signal).

When the STA signal and NE signal are input to the ECM, Tr is turned ON, current flows to the coil of the circuit opening relay, the relay switches on, power is supplied to the fuel pump and the fuel pump operates. While the NE signal is generated (engine running), the ECM keeps Tr ON (circuit opening relay ON) and the fuel pump also keeps operating.

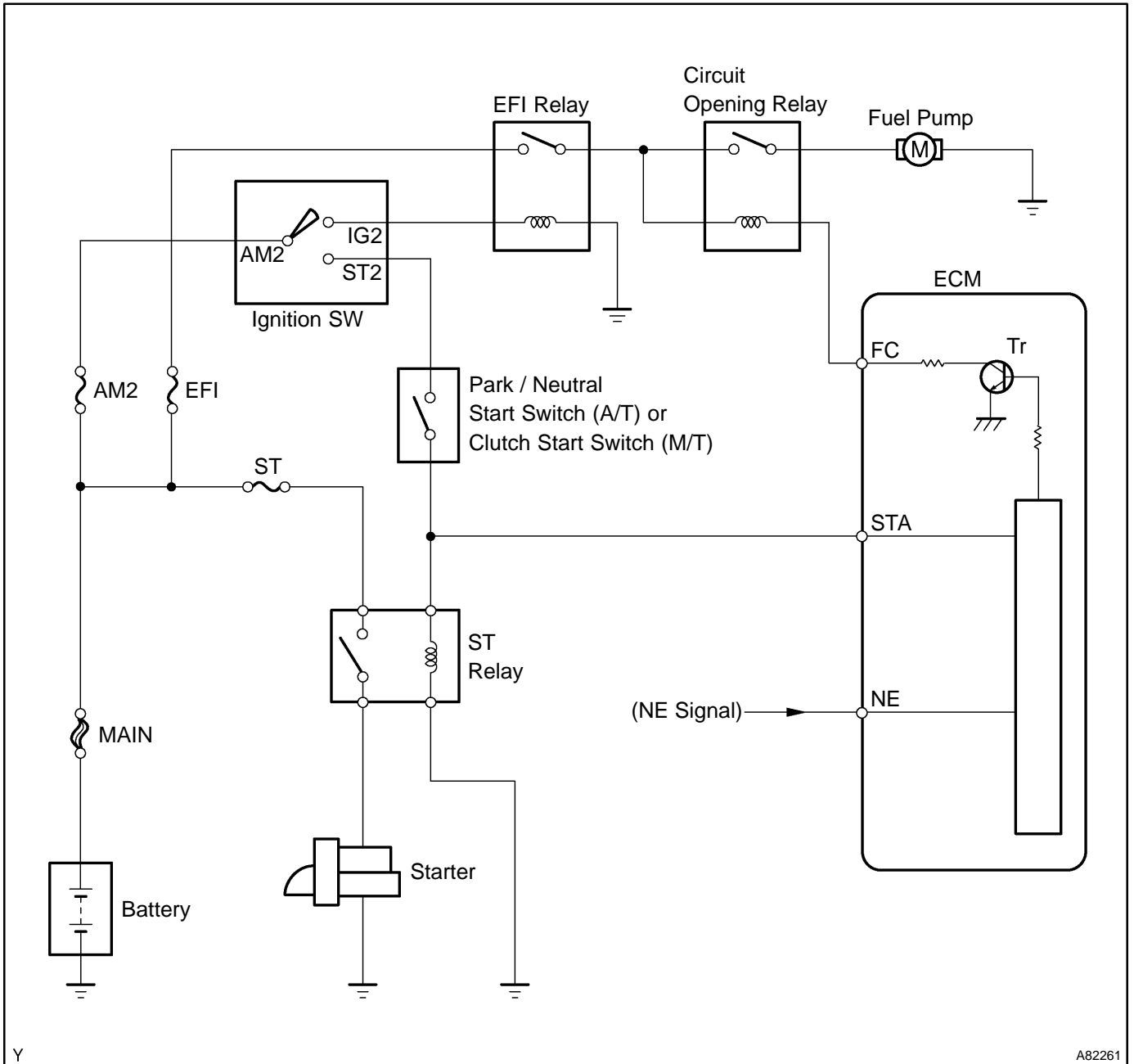

Y

A82261

WIRING DIAGRAM

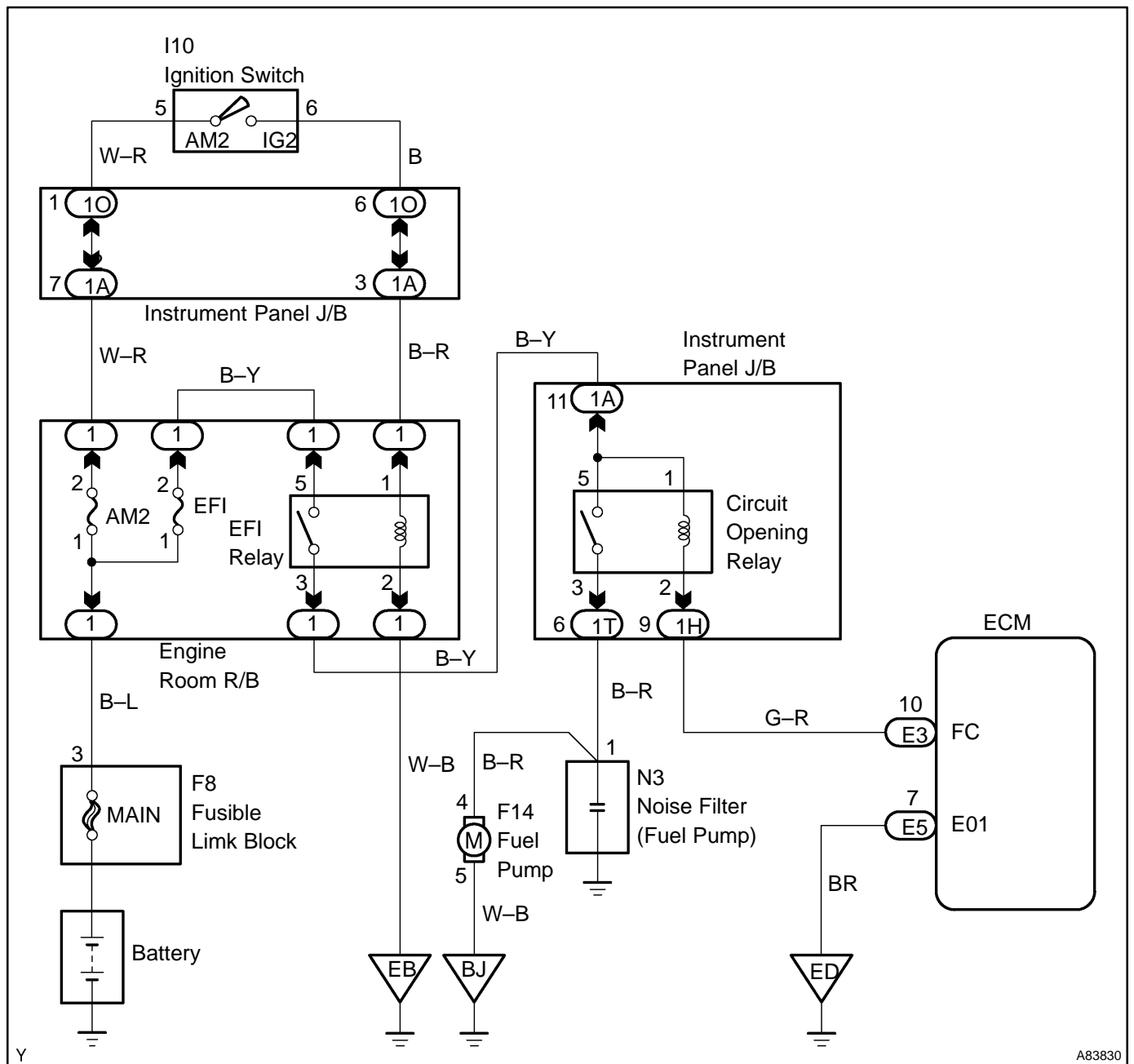

Y

A83830

## INSPECTION PROCEDURE

### Hand-held tester:

**1 PERFORM ACTIVE TEST BY HAND-HELD TESTER(OPERATION OF CIRCUIT OPENING RELAY)**

- (a) Connect the hand-held tester to the DLC3.
- (b) Turn the ignition switch ON and push the hand-held tester main switch ON.
- (c) Select the item "DIAGNOSIS / ENHANCED OBD II / ACTIVE TEST / FUEL PUMP / SPD".
- (d) Check the relay operation while operating it with the hand-held tester.

**Standard: Operating noise can be heard from the relay.**

**OK** → Go to step 7

**NG**

**2 CHECK ECM POWER SOURCE CIRCUIT (See page 05-239)**

**NG** → REPAIR OR REPLACE POWER SOURCE CIRCUIT

**OK**

**3 INSPECT CIRCUIT OPENING RELAY**

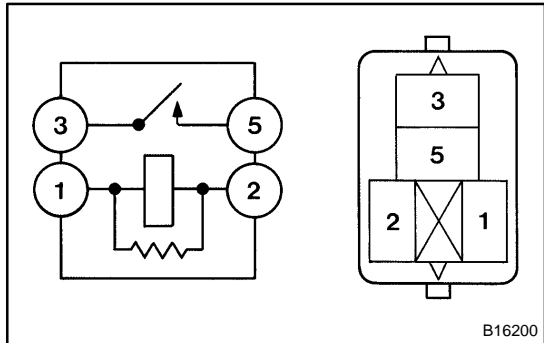

- (a) Remove the circuit opening relay from the instrument panel J/B.
- (b) Inspect the circuit opening relay.

**Standard:**

Tester Connection	Specified Condition
1 - 2	Below 1 Ω
3 - 5	10 kΩ or higher
	Below 1 Ω (Apply battery voltage to terminals 1 and 2)

- (c) Reinstall the circuit opening relay.

**NG** → REPLACE CIRCUIT OPENING RELAY

**OK**

**4 INSPECT ECM(FC VOLTAGE)**

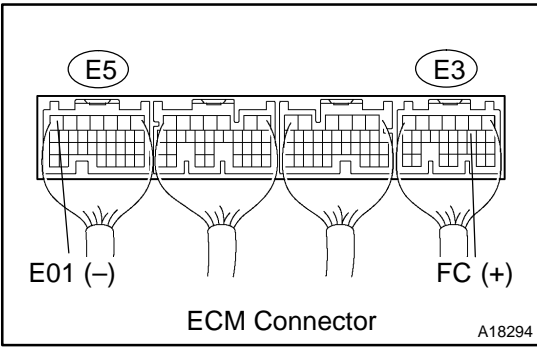

- (a) Turn the ignition switch ON.
- (b) Measure the voltage between the specified terminals of the E3 and E5 ECM connectors.

**Standard:**

Tester Connection	Specified Condition
FC (E3-10) – E01 (E5-7)	9 to 14 V

**OK** → **REPLACE ECM**

**NG**

**5 CHECK HARNESS AND CONNECTOR(EFI RELAY – CIRCUIT OPENING RELAY)**

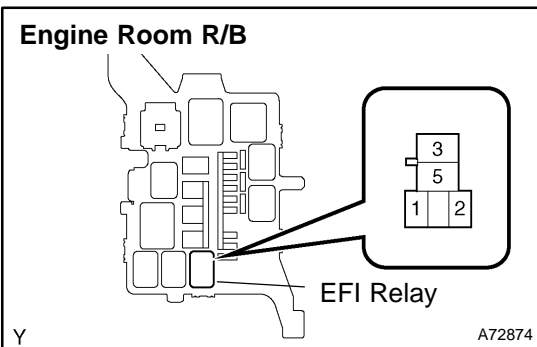

- (a) Remove the EFI relay from the engine room R/B.
- (b) Remove the circuit opening relay from the instrument panel J/B.
- (c) Measure the resistance between the wire harness side connectors.

**Standard (Check for open):**

Tester Connection	Specified Condition
EFI relay (3) – Circuit opening relay (1)	Below 1 Ω
EFI relay (3) – Circuit opening relay (5)	

**Standard (Check for short):**

Tester Connection	Specified Condition
EFI relay (3) or Circuit opening relay (1) – Body ground	10 kΩ or higher
EFI relay (3) or Circuit opening relay (5) – Body ground	

- (d) Reinstall the EFI relay.
- (e) Reinstall the circuit opening relay.

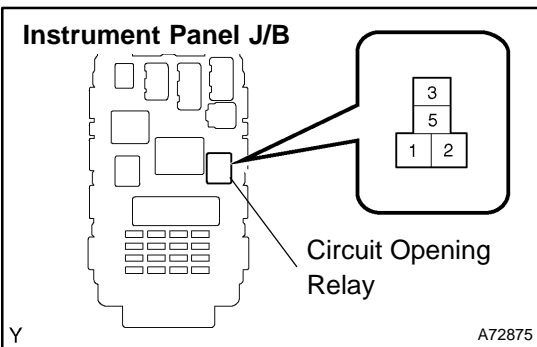

**NG** → **REPAIR OR REPLACE HARNESS OR CONNECTOR**

**OK**

**6 CHECK HARNESS AND CONNECTOR(ECM - CIRCUIT OPENING RELAY)**

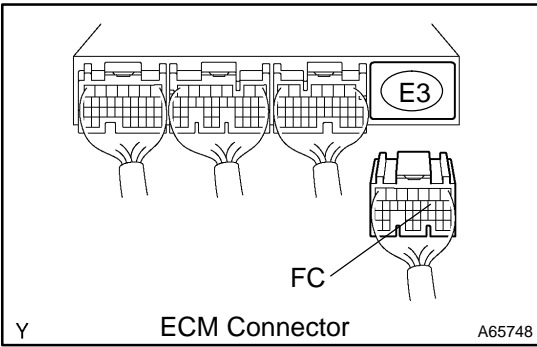

- (a) Disconnect the E3 ECM connector.
- (b) Remove the circuit opening relay from the instrument panel J/B.
- (c) Measure the resistance between the wire harness side connectors.

**Standard (Check for open):**

Tester Connection	Specified Condition
FC (E3-10) - Circuit opening relay (2)	Below 1 Ω

**Standard (Check for short):**

Tester Connection	Specified Condition
FC (E3-10) - Circuit opening relay (2) - Body ground	10 kΩ or higher

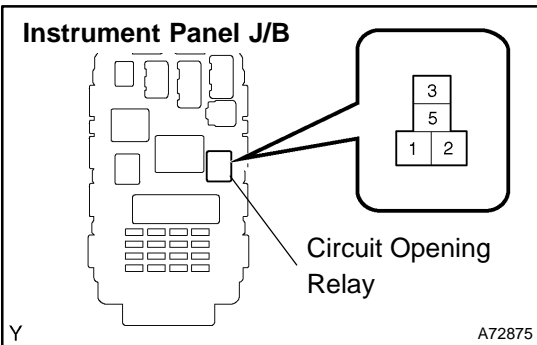

- (d) Reconnect the ECM connector.
- (e) Reinstall the circuit opening relay.

**NG** → **REPAIR OR REPLACE HARNESS OR CONNECTOR**

**OK**

**REPLACE ECM (See page 10-17)**

**7 INSPECT FUEL PUMP ASSY (See page 11-7)**

**NG** → **REPAIR OR REPLACE FUEL PUMP ASSY**

**OK**

**8 CHECK HARNESS AND CONNECTOR(CIRCUIT OPENING RELAY – FUEL PUMP, FUEL PUMP – BODY GROUND)**

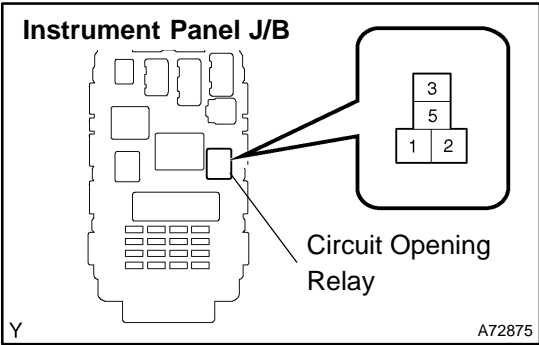

- (a) Remove the circuit opening relay from the instrument panel J/B.
- (b) Disconnect the F14 fuel pump connector.
- (c) Measure the resistance between the wire harness side connectors.

**Standard (Check for open):**

Tester Connection	Specified Condition
Circuit opening relay (3) – Fuel pump (F14-4)	Continuity
Fuel pump (F14-5) – Body ground	

**Standard (Check for short):**

Tester Connection	Specified Condition
Circuit opening relay (3) or Fuel pump (F14-4) – Body ground	10 kΩ or higher

- (d) Reconnect the fuel pump connector.
- (e) Reinstall the circuit opening relay.

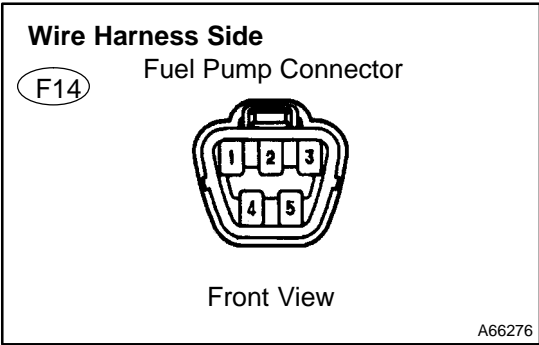

**NG** → **REPAIR OR REPLACE HARNESS OR CONNECTOR**

**OK**

**REPLACE ECM (See page 10-17)**

**OBD II scan tool (excluding hand-held tester):**

**1 CHECK OPERATION OF FUEL PUMP**

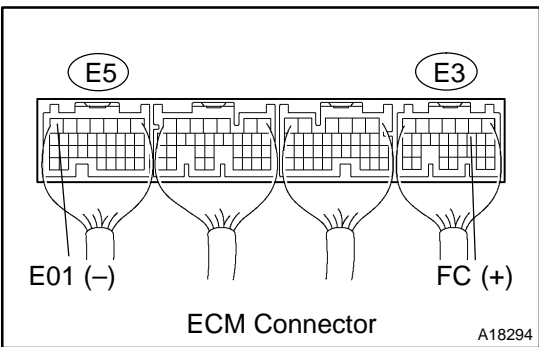

- (a) Turn the ignition switch ON.
- (b) Connect between terminals FC and E01 of the ECM connector.
- (c) Check for fuel pressure in the fuel inlet hose when it is pinched off.

**Result: There is pressure in fuel inlet hose.**

**HINT:**  
At this time, you will hear the fuel flowing sound.

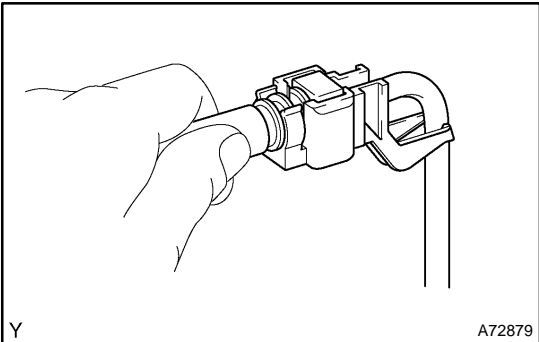

**OK** → **PROCEED TO NEXT CIRCUIT INSPECTION SHOWN ON PROBLEM SYMPTOMS TABLE (See page 05-42)**

**NG**

**2 | CHECK ECM POWER SOURCE CIRCUIT (See page 05-239)**

**NG** → **REPAIR OR REPLACE POWER SOURCE CIRCUIT**

**OK**

**3 | INSPECT CIRCUIT OPENING RELAY**

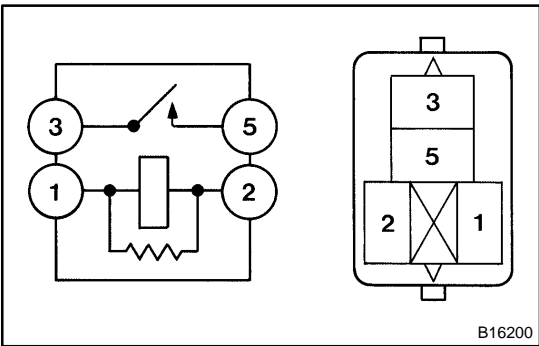

- (a) Remove the circuit opening relay from the instrument panel J/B.
- (b) Inspect the circuit opening relay.

**Standard:**

Tester Connection	Specified Condition
1 - 2	Below 1 Ω
3 - 5	10 kΩ or higher
	Below 1 Ω (Apply battery voltage to terminals 1 and 2)

- (c) Reinstall the circuit opening relay.

**NG** → **REPLACE CIRCUIT OPENING RELAY**

**OK**

**4 | INSPECT ECM(FC VOLTAGE)**

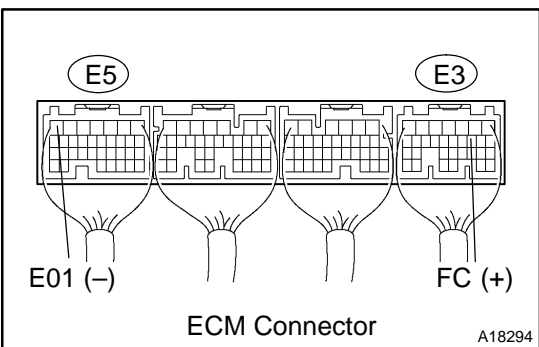

- (a) Turn the ignition switch ON.
- (b) Measure the voltage between the specified terminals of the E3 and E5 ECM connectors.

**Standard:**

Tester Connection	Specified Condition
FC (E3-10) - E01 (E5-7)	9 to 14 V

**OK** → **Go to step 7**

**NG**

**5 CHECK HARNESS AND CONNECTOR(EFI RELAY – CIRCUIT OPENING RELAY)**

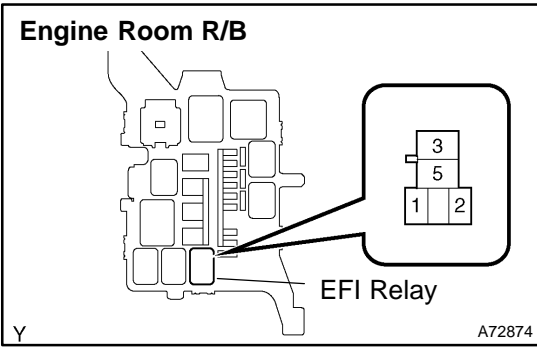

- (a) Remove the EFI relay from the engine room R/B.
- (b) Remove the circuit opening relay from the instrument panel J/B.
- (c) Measure the resistance between the wire harness side connectors.

**Standard (Check for open):**

Tester Connection	Specified Condition
EFI relay (3) – Circuit opening relay (1)	Below 1 Ω
EFI relay (3) – Circuit opening relay (5)	

**Standard (Check for short):**

Tester Connection	Specified Condition
EFI relay (3) or Circuit opening relay (1) – Body ground	10 kΩ or higher
EFI relay (3) or Circuit opening relay (5) – Body ground	

- (d) Reinstall the EFI relay.
- (e) Reinstall the circuit opening relay.

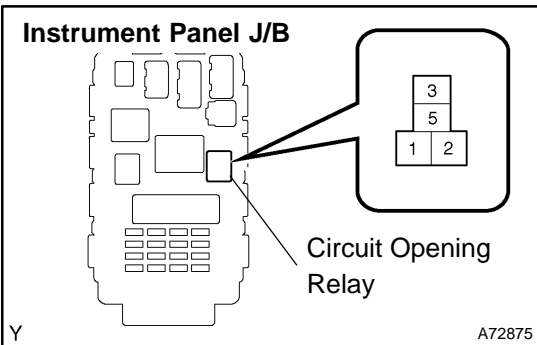

**NG REPAIR OR REPLACE HARNESS OR CONNECTOR**

**OK**

**6 CHECK HARNESS AND CONNECTOR(ECM – CIRCUIT OPENING RELAY)**

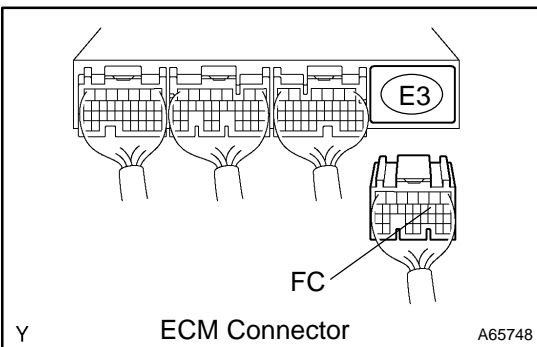

- (a) Disconnect the E3 ECM connector.
- (b) Remove the circuit opening relay from the instrument panel J/B.
- (c) Measure the resistance between the wire harness side connectors.

**Standard (Check for open):**

Tester Connection	Specified Condition
FC (E3-10) – Circuit opening relay (2)	Below 1 Ω

**Standard (Check for short):**

Tester Connection	Specified Condition
FC (E3-10) – Circuit opening relay (2) – Body ground	10 kΩ or higher

- (d) Reconnect the ECM connector.
- (e) Reinstall the circuit opening relay.

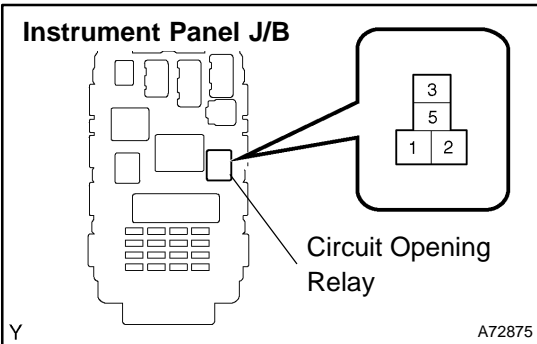

**NG REPAIR OR REPLACE HARNESS OR CONNECTOR**

**OK**

**REPLACE ECM (See page 10-17)**

**7 INSPECT FUEL PUMP ASSY (See page 11-7)**

**NG** REPAIR OR REPLACE FUEL PUMP ASSY

**OK**

**8 CHECK HARNESS AND CONNECTOR(CIRCUIT OPENING RELAY - FUEL PUMP, FUEL PUMP - BODY GROUND)**

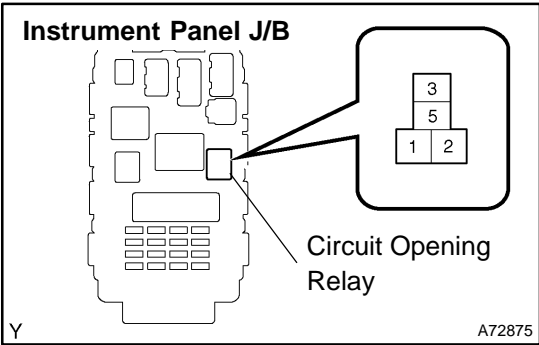

- (a) Remove the circuit opening relay from the instrument panel J/B.
- (b) Disconnect the F14 fuel pump connector.
- (c) Measure the resistance between the wire harness side connectors.

**Standard (Check for open):**

Tester Connection	Specified Condition
Circuit opening relay (3) - Fuel pump (F14-4)	Continuity
Fuel pump (F14-5) - Body ground	

**Standard (Check for short):**

Tester Connection	Specified Condition
Circuit opening relay (3) or Fuel pump (F14-4) - Body ground	10 kΩ or higher

- (d) Reconnect the fuel pump connector.
- (e) Reinstall the circuit opening relay.

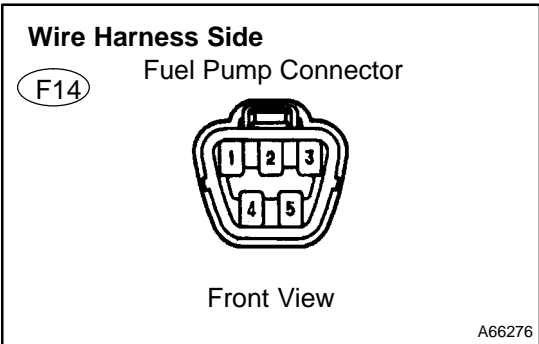

**NG** REPAIR OR REPLACE HARNESS OR CONNECTOR

**OK**

**REPLACE ECM (See page 10-17)**