

DTC	P0451(A)	EVAPORATIVE EMISSION CONTROL SYSTEM PRESSURE SENSOR/SWITCH RANGE/PERFORMANCE
------------	-----------------	---

DTC	P0452	EVAPORATIVE EMISSION CONTROL SYSTEM PRESSURE SENSOR/SWITCH LOW INPUT
------------	--------------	---

DTC	P0453	EVAPORATIVE EMISSION CONTROL SYSTEM PRESSURE SENSOR/SWITCH HIGH INPUT
------------	--------------	--

CIRCUIT DESCRIPTION

The vapor pressure sensor, VSV for canister closed valve (CCV) and VSV for pressure switching valve are used to detect abnormalities in the evaporative emission control system.

The ECM decides whether there is an abnormality in the evaporative emission control system based on the vapor pressure sensor signal.

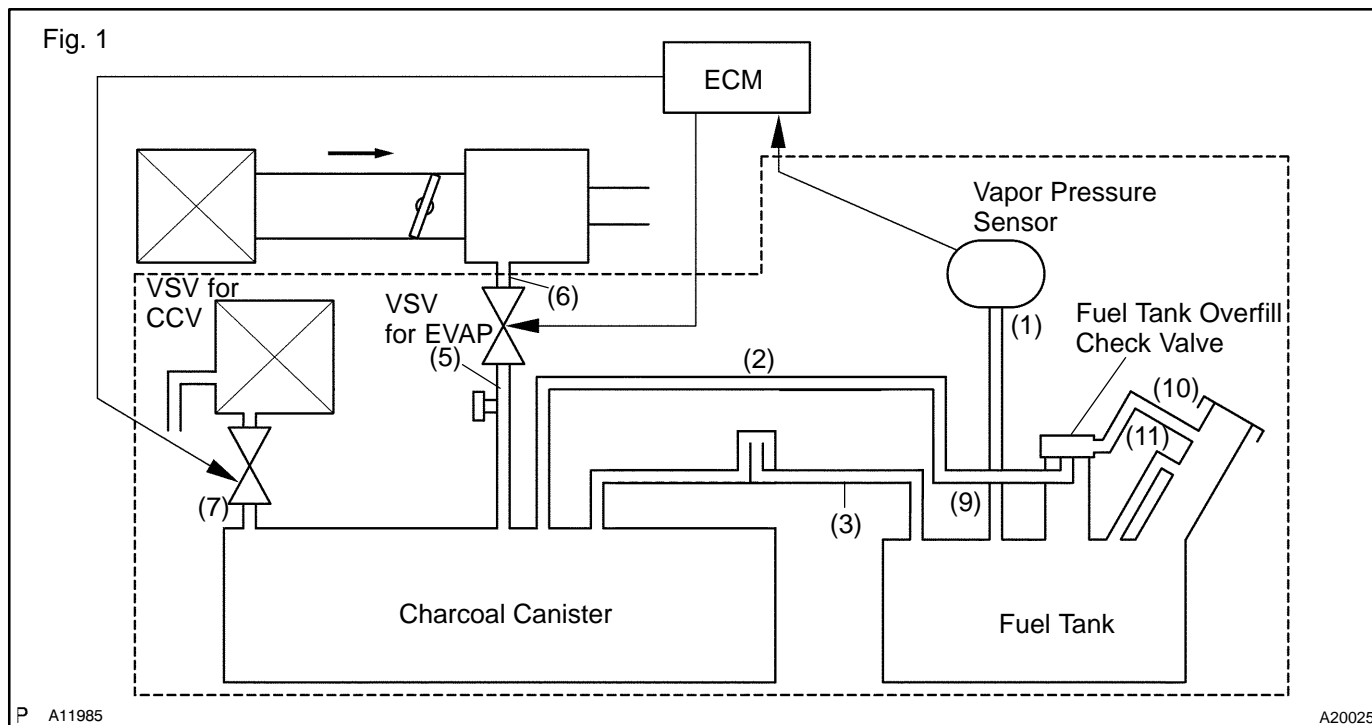

DTC No.	DTC Detection Condition	Trouble Area
P0451	Vapor pressure sensor output changes extremely under conditions: Vehicle speed: 0 mph (0km/h) and the engine speed: Idling or vapor pressure sensor output stuck 5 min after engine start. (2 trip detection logic)	<ul style="list-style-type: none"> • Open or short in vapor pressure sensor circuit • Vapor pressure sensor • ECM
P0452	Vapor pressure sensor output remains less than specific value: (2 trip detection logic)	
P0453	Vapor pressure sensor output remains more than specific value: (2 trip detection logic)	

MONITOR DESCRIPTION

DTC "P0451, P0452 or P0453" is recorded by the ECM when the vapor pressure sensor malfunctions.

P0451

The ECM senses pressure in the fuel tank using the vapor pressure sensor. The ECM supplies the sensor with a regulated 5 V reference-voltage and the sensor returns a signal voltage between 0.5 V and 4.5 V according to the pressure level in the fuel tank.

When the pressure in the fuel tank is low, the output voltage of the vapor pressure sensor is low. When it is high, the output voltage is high.

For this DTC P0451, the ECM checks for a "noisy" sensor or a "stuck" sensor.

The ECM checks for the "noisy" sensor by monitoring the fuel tank pressures when the vehicle is stationary and there should be little variation in the tank pressure. If the indicated pressure varies beyond specified limits, the ECM will illuminate the MIL and a DTC is set.

The ECM checks for the "stuck" sensor by monitoring the fuel tank pressure for an extended time period. If the indicated pressure does not change over this period, the ECM will conclude that the fuel tank pressure sensor is malfunctioning. The ECM will illuminate the MIL and a DTC is set.

P0452 and P0453

The ECM senses pressure in the fuel tank using the vapor pressure sensor. The ECM supplies the sensor with a regulated 5 V reference-voltage and the sensor returns a signal voltage between 0.5 V and 4.5 V according to the pressure level in the fuel tank.

When the pressure in the fuel tank is low, the output voltage of the vapor pressure sensor is low. When it is high, the output voltage is high.

If the output voltage of the vapor pressure sensor is out of the normal range, the ECM will determine that there is a malfunction in the sensor or sensor circuit.

When pressure indicated by the vapor pressure sensor deviates below -3.999 kpa (-30 mmHg) or above 1.999 kpa (15 mmHg), the ECM interprets this as a malfunction in the vapor pressure sensor. The ECM will turn on the MIL and a DTC will be set.

MONITOR STRATEGY

P0451

Related DTCs	P0451	Evaporative emission control system pressure sensor range/performance
Required sensors/components	Main sensors	Vapor pressure sensor
	Related sensors	Mass air flow meter, engine coolant temperature sensor
Frequency of operation	Once per driving cycle	
Duration	Signal fluctuation (noise) monitoring: 10 sec No signal change (stuck) monitoring: 20 min	
MIL operation	2 driving cycles	
Sequence of operation	None	

P0452 and P0453

Related DTCs	P0452	Evaporative emission control system pressure sensor/switch low input
	P0453	Evaporative emission control system pressure sensor/switch high input
Required sensors/components	Main sensors	Vapor pressure sensor
	Related sensors	Mass air flow meter, engine coolant temperature sensor
Frequency of operation	Once per driving cycle	
Duration	17 sec	
MIL operation	2 driving cycles	
Sequence of operation	None	

TYPICAL ENABLING CONDITIONS**P0451**

Item	Specification	
	Minimum	Maximum
The monitor will run whenever the following DTCs are not present	See "List of Disable a Monitor" table (On page 05-24)	
Signal fluctuation (noise) monitoring:		
Altitude	–	2,400 m (7,872 ft)
Battery voltage	11 V	–
Difference between intake air temperature and engine coolant temperature at engine start	–7°C (19.4°F)	11.1°C (52°F)
Engine coolant temperature at engine start	4.4°C (40°F)	35°C (95°F)
Intake coolant temperature at engine start	4.4°C (40°F)	35°C (95°F)
Vehicle stop and idling	5 sec	15 sec
Stuck monitoring:		
Altitude	–	2,400 m (7,872 ft)
Battery voltage	11 V	–
Vapor pressure sensor	No malfunction	
Difference between intake air temperature and engine coolant temperature at engine start	–7°C (19.4°F)	11.1°C (52°F)
Engine coolant temperature at engine start	4.4°C (40°F)	35°C (95°F)
Intake air coolant temperature at engine start	4.4°C (40°F)	35°C (95°F)

P0452 and P0453

Item	Specification	
	Minimum	Maximum
The monitor will run whenever the following DTCs are not present	See "List of Disable a Monitor" table (On page 05-24)	
Difference between intake air temperature and engine coolant temperature at engine start	–	12°C (54°F)
Engine coolant temperature at engine start	10°C (50°F)	35°C (95°F)
Intake air temperature at engine start	10°C (50°F)	35°C (95°F)
Engine	Running	

TYPICAL MALFUNCTION THRESHOLDS

P0451

Detection criteria	Threshold
Signal fluctuation (noise) monitoring:	
The number of times the output changed ± 0.7 kpa (5 mmHg) or more during 5 to 15 seconds after idling and vehicle stop	7 times or more
No signal change (stuck) monitoring:	
Fuel tank pressure "no change" time (less than 0.138 kpa (0.02 mmHg) change since engine start)	20 min or more

P0452 and P0453

Detection criteria	Threshold
P0452:	
Fuel tank pressure	Less than -3.999 kPa (-30 mmHg) / when engine running
P0453:	
Fuel tank pressure	1.999 kPa (15 mmHg) or more / when engine running

WIRING DIAGRAM

Refer to DTC P0441 and P0446 on page [05-180](#).

INSPECTION PROCEDURE

HINT:

- If different DTCs related to different systems that have terminal E2 as the ground terminal are output simultaneously, terminal E2 may be open.
- If DTC P0441 (Purge Flow), P0446 (VSV for CCV), P0451, P0452 or P0453 (Evaporative Pressure Sensor) is output with DTC P0442 or P0456, troubleshoot DTC P0441, P0446, P0451, P0452 or P0453 first. If no malfunction is detected, troubleshoot DTC P0442 or P0456 next.
- Read freeze frame data using the hand-held tester or the OBD II scan tool. Freeze frame data records the engine conditions when a malfunction is detected. When troubleshooting, it is useful for determining whether the vehicle was running or stopped, the engine was warmed up or not, the air-fuel ratio was lean or rich, etc. at the time of the malfunction.
- If the ENGINE RUN TIME in the freeze frame data is less than 200 seconds, carefully check the vapor pressure sensor.

1 INSPECT ECM(VC VOLTAGE)

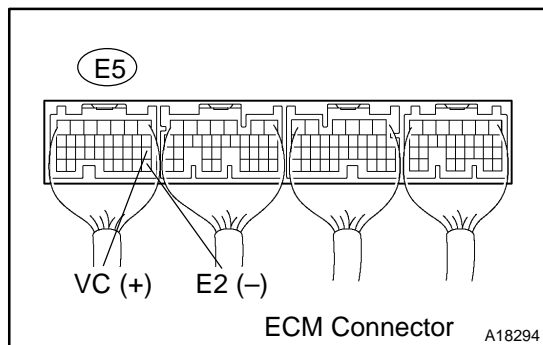

- Turn the ignition switch ON.
- Measure the voltage between the specified terminals of the E5 ECM connector.

Standard:

Tester Connection	Specified Condition
VC (E5-18) – E2 (E5-28)	4.5 to 5.5 V

NG

REPLACE ECM (See page [10-17](#))

OK

2 INSPECT ECM(PTNK VOLTAGE)

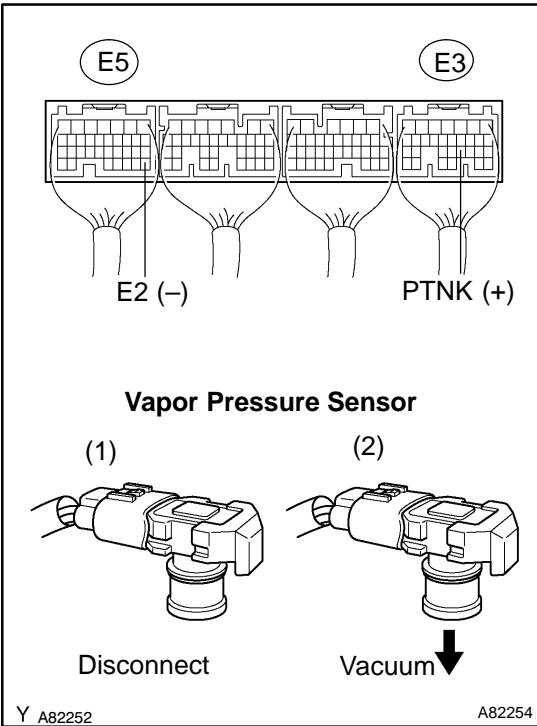

- (a) Turn the ignition switch ON.
- (b) Measure the voltage between the specified terminals of the E3 and E5 ECM connectors.
 - (1) Remove the vapor pressure sensor.

Standard (1):

Tester Connection	Specified Condition
PTNK (E3-21) – E2 (E5-28)	2.9 to 3.7 V

- (2) Using the MITYVAC (Hand-Held Vacuum Pump), apply a vacuum of 4.0 kPa (30 mmHg, 1.18 in.Hg) to the vapor pressure sensor.

NOTICE:

The vacuum applied to the vapor pressure sensor must be less than 66.7 kPa (500 mmHg, 19.7 in.Hg).

Standard (2):

Tester Connection	Specified Condition
PTNK (E3-21) – E2 (E5-28)	0.5 V or less

- (3) Reinstall the vapor pressure sensor.

OK → **REPLACE ECM (See page 10-17)**

NG

3 CHECK HARNESS AND CONNECTOR(VAPOR PRESSURE SENSOR – ECM)

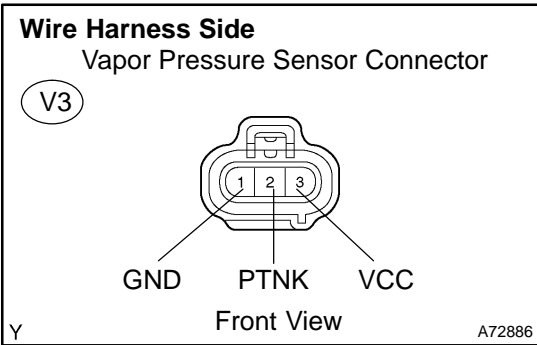

- (a) Disconnect the V3 vapor pressure sensor connector.
- (b) Disconnect the E3 and E5 ECM connectors.
- (c) Measure the resistance between the wire harness side connectors.

Standard (Check for open):

Tester Connection	Specified Condition
PTNK (V3-2) – PTNK (E3-21)	Below 1 Ω
GND (V3-1) – E2 (E5-28)	
VCC (V3-3) – VC (E5-18)	

Standard (Check for short):

Tester Connection	Specified Condition
PTNK (V3-2) or PTNK (E3-21) – Body ground	10 kΩ or higher
VCC (V3-3) or VC (E5-18) – Body ground	

- (d) Reconnect the vapor pressure sensor connector.
- (e) Reconnect the ECM connector.

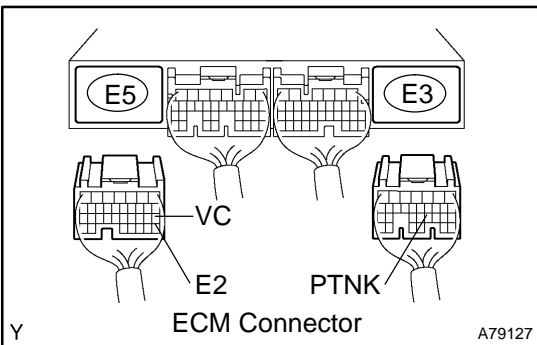

NG → **REPAIR OR REPLACE HARNESS OR CONNECTOR**

OK

REPLACE VAPOR PRESSURE SENSOR ASSY