

DTC	P0115	ENGINE COOLANT TEMPERATURE CIRCUIT
------------	--------------	---

DTC	P0117	ENGINE COOLANT TEMPERATURE CIRCUIT LOW INPUT
------------	--------------	---

DTC	P0118	ENGINE COOLANT TEMPERATURE CIRCUIT HIGH INPUT
------------	--------------	--

CIRCUIT DESCRIPTION

A thermistor is built in the engine coolant temperature sensor and changes the resistance value according to the engine coolant temperature.

The structure of the sensor and connection to the ECM is the same as those of the intake air temperature sensor.

HINT:

If the ECM detects the DTC "P0115, P0117 or P0118", it operates the fail-safe function in which the engine coolant temperature is assumed to be 80 °C (176 °F).

DTC No.	Proceed to	DTC Detection Condition	Trouble Area
P0115	Step 1	Open or short in engine coolant temp. sensor circuit for 0.5 sec.	<ul style="list-style-type: none"> • Open or short in engine coolant temperature sensor circuit • Engine coolant temperature sensor • ECM
P0117	Step 4	Short in engine coolant temp. sensor circuit for 0.5 sec.	
P0118	Step 2	Open in engine coolant temp. sensor circuit for 0.5 sec.	

HINT:

After confirming DTC "P0115, P0117 or P0118", use the hand-held tester or the OBD II scan tool to confirm the engine coolant temperature from the "DIAGNOSIS/ENHANCED OBD II/DATA LIST/ALL".

Temperature Displayed	Malfunction
-40°C (-40°F)	Open circuit
140°C (284°F) or more	Short circuit

MONITOR DESCRIPTION

The engine coolant temperature (ECT) sensor is used to monitor the engine coolant temperature. The ECT sensor has a thermistor that varies its resistance depending on the temperature of the engine coolant. When the coolant temperature is low, the resistance in the thermistor increases. When the temperature is high, the resistance drops. The variations in resistance are reflected in the voltage output from the sensor. The ECM monitors the sensor voltage and uses this value to calculate the engine coolant temperature. When the sensor output voltage deviates from the normal operating range, the ECM interprets this as a fault in the ECT sensor and sets a DTC.

Example:

When the ECM calculates that the ECT is -40°C (-40°F), or more than 140°C (284°F), and if either condition continues for 0.5 sec or more, the ETC will set a DTC.

MONITOR STRATEGY

Related DTCs	P0115	Engine coolant temperature sensor range check (fluttering)
	P0117	Engine coolant temperature sensor range check (low resistance)
	P0118	Engine coolant temperature sensor range check (high resistance)
Required sensors/components	Engine coolant temperature sensor	
Frequency of operation	Continuous	
Duration	0.5 sec	
MIL operation	Immediately	
Sequence of operation	None	

TYPICAL ENABLING CONDITIONS

The monitor will run whenever the following DTCs are not present	See "List of Disable a Monitor" table (On page 05-24)
--	---

TYPICAL MALFUNCTION THRESHOLDS

Detection Criteria	Threshold
P0115:	
Engine coolant temperature sensor resistance (coolant temperature)	Less than 79 Ω or more than 156 kΩ (more than 140°C (284°F) or -40°C (-40°F) or less)
P0117:	
Engine coolant temperature sensor resistance (coolant temperature)	Less than 79 Ω (more than 140°C (284°F))
P0118:	
Engine coolant temperature sensor resistance (coolant temperature)	More than 156 kΩ (-40°C (-40°F) or less)

COMPONENT OPERATING RANGE

Parameter	Standard Value
Engine coolant temperature sensor resistance	79 Ω (140°C (281°F)) to 156 kΩ (-40°C (-40°F))

WIRING DIAGRAM

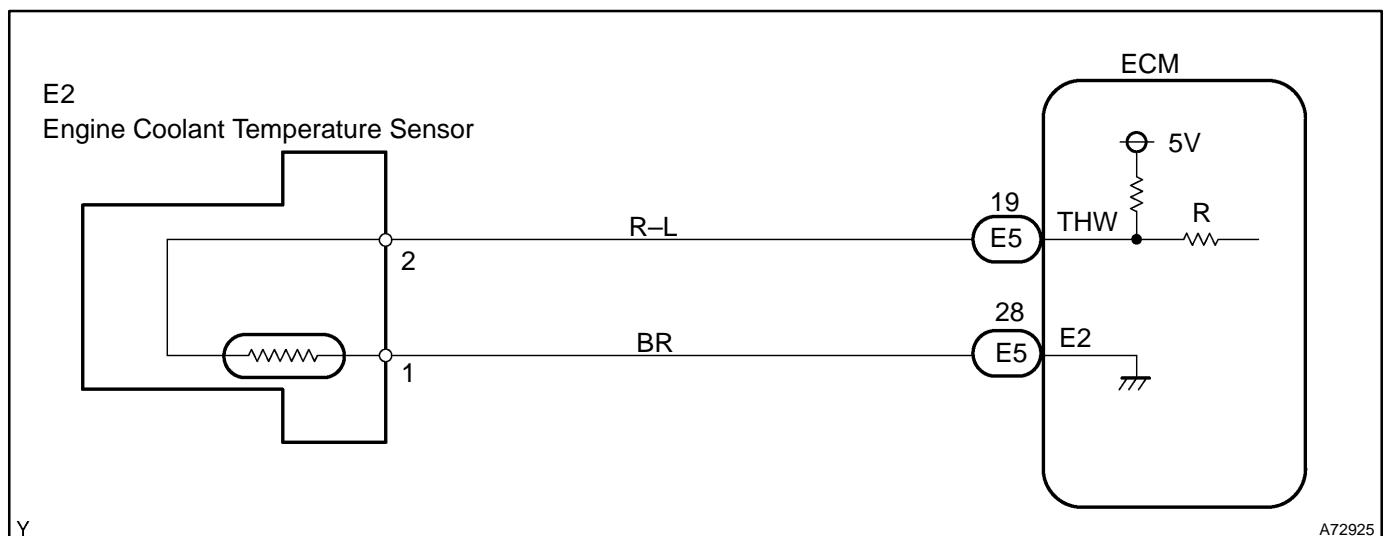

Y

A72925

INSPECTION PROCEDURE

HINT:

- If different DTCs related to different systems that have terminal E2 as the ground terminal are output simultaneously, terminal E2 may be open.
- Read freeze frame data using the hand-held tester or the OBD II scan tool. Freeze frame data records the engine conditions when a malfunction is detected. When troubleshooting, it is useful for determining whether the vehicle was running or stopped, the engine was warmed up or not, the air-fuel ratio was lean or rich, etc. at the time of the malfunction.

1	READ VALUE OF HAND-HELD TESTER OR OBD II SCAN TOOL(ENGINE COOLANT TEMPERATURE)
----------	---

- Connect the hand-held tester or the OBD II scan tool to the DLC3.
- Turn the ignition switch ON and push the hand-held tester or the OBD II scan tool main switch ON.
- Select the item "DIAGNOSIS / ENHANCED OBD II / DATA LIST / ALL / COOLANT TEMP" and read its value displayed on the hand-held tester or the OBD II scan tool.

Temperature: Same value as the actual intake air temperature.

Result:

Temperature Displayed	Proceed to
-40°C (-40°F)	A
140°C (284°F) or more	B
OK (Same as present temperature)	C

HINT:

- If there is an open circuit, the hand-held tester or the OBD II scan tool indicates -40°C (-40°F).
- If there is a short circuit, the hand-held tester or the OBD II scan tool indicates 140°C (284°F) or more.

B

Go to step 4

C

**CHECK FOR INTERMITTENT PROBLEMS
(See page 05-41)**

A

2 READ VALUE OF HAND-HELD TESTER OR OBD II SCAN TOOL(CHECK FOR OPEN IN WIRE HARNESS)

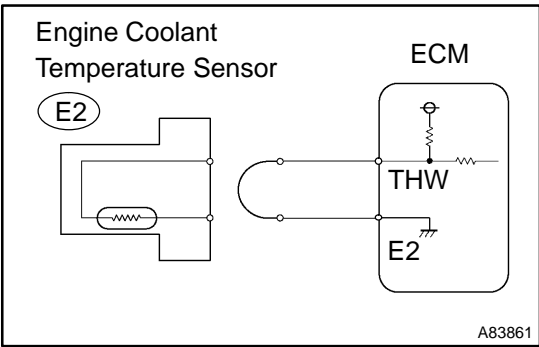

- (a) Disconnect the E2 engine coolant temperature sensor connector.
- (b) Connect terminals 1 and 2 of the engine coolant temperature sensor wire harness side connector.
- (c) Turn the ignition switch ON.
- (d) Select the item "DIAGNOSIS / ENHANCED OBD II / DATA LIST / ALL / COOLANT TEMP" and read its value displayed on the hand-held tester or the OBD II scan tool.
Temperature value: 140°C (284°F) or more
- (e) Reconnect the engine coolant temperature sensor connector.

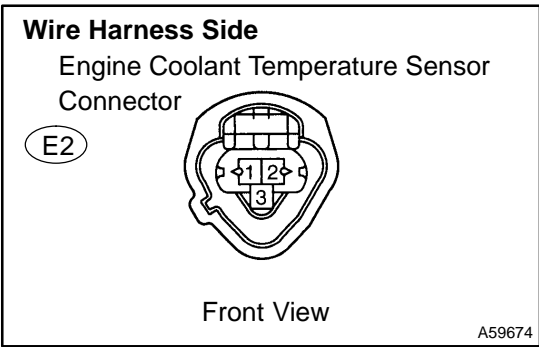

OK → **CONFIRM GOOD CONNECTION AT SENSOR. IF OK, REPLACE ENGINE COOLANT TEMP. SENSOR**

NG

3 READ VALUE OF HAND-HELD TESTER OR OBD II SCAN TOOL(CHECK FOR OPEN IN ECM)

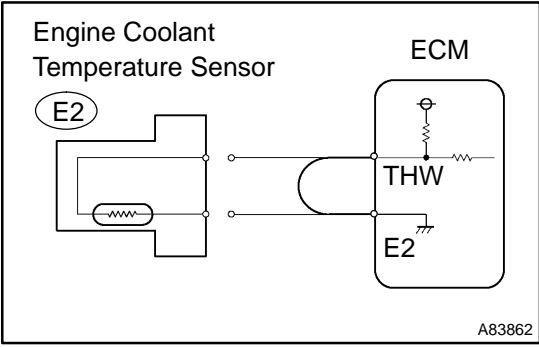

- (a) Disconnect the E2 engine coolant temperature sensor connector.
- (b) Connect terminals THW and E2 of the E5 ECM connector.
HINT: Before checking, do a visual and contact pressure check for the ECM connector.
- (c) Turn the ignition switch ON.
- (d) Select the item "DIAGNOSIS / ENHANCED OBD II / DATA LIST / ALL / COOLANT TEMP" and read its value displayed on the hand-held tester or the OBD II scan tool.
Temperature value: 140°C (284°F) or more
- (e) Reconnect the engine coolant temperature sensor connector.

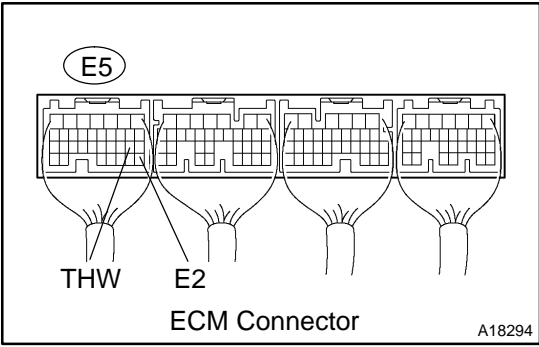

OK → **REPAIR OR REPLACE HARNESS OR CONNECTOR**

NG

CONFIRM GOOD CONNECTION AT ECM. IF OK, REPLACE ECM (See page 10-17)

4 READ VALUE OF HAND-HELD TESTER OR OBD II SCAN TOOL(CHECK FOR SHORT IN WIRE HARNESS)

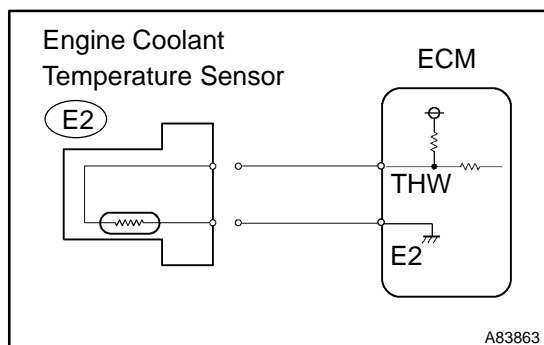

- Disconnect the E2 engine coolant temperature sensor connector.
- Turn the ignition switch ON.
- Select the item "DIAGNOSIS / ENHANCED OBD II / DATA LIST / ALL / COOLANT TEMP" and read its value displayed on the hand-held tester or the OBD II scan tool.
Temperature value: -40°C (-40°F)
- Reconnect the engine coolant temperature sensor connector.

OK

REPLACE ENGINE COOLANT TEMPERATURE SENSOR

NG

5 READ VALUE OF HAND-HELD TESTER OR OBD II SCAN TOOL(CHECK FOR SHORT IN ECM)

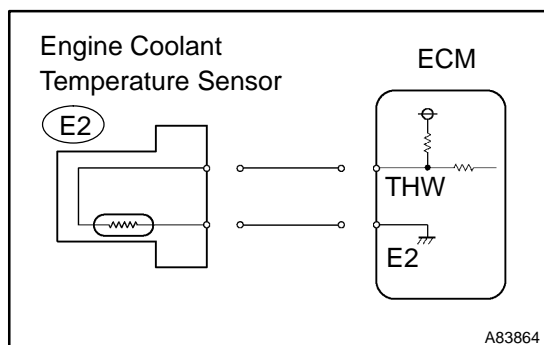

- Disconnect the E5 ECM connector.
- Turn the ignition switch ON.
- Select the item "DIAGNOSIS / ENHANCED OBD II / DATA LIST / ALL / COOLANT TEMP" and read its value displayed on the hand-held tester or the OBD II scan tool.
Temperature: -40°C (-40°F)
- Reconnect the ECM connector.

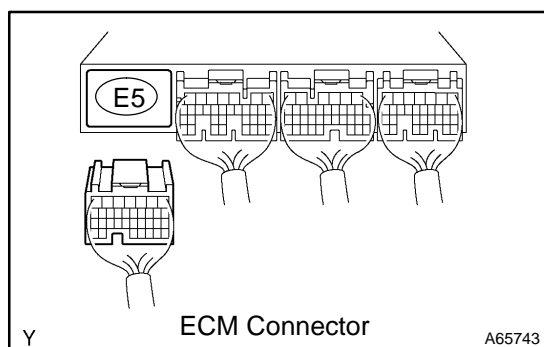

OK

REPAIR OR REPLACE HARNESS OR CONNECTOR

NG

REPLACE ECM (See page 10-17)