

## CHECK MODE PROCEDURE

### HINT:

Hand-held tester only:

Compared to the normal mode, the check mode has more sensing ability to detect malfunctions. Furthermore, the same diagnostic items which are detected in the normal mode can also be detected in the check mode.

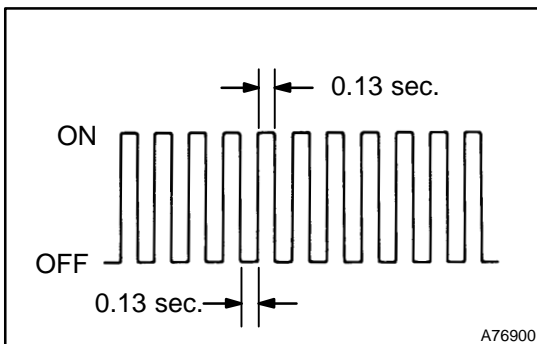
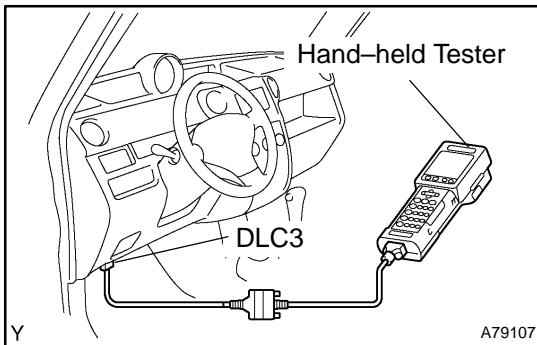

### 1. CHECK MODE PROCEDURE(Using the hand-held tester)

- (a) Check the initial conditions.
  - (1) Battery positive voltage 11 V or more
  - (2) Throttle valve fully closed
  - (3) Transmission in the P or N position
  - (4) A/C switched OFF
- (b) Turn the ignition switch OFF.
- (c) Connect the hand-held tester to the DLC3.
- (d) Turn the ignition switch ON.
- (e) Switch the hand-held tester from the normal mode to the check mode (check that the MIL flashes).

### NOTICE:

**If the hand-held tester switches the ECM from the normal mode to the check mode or vice-versa, or if the ignition switch is turned from ON to ACC or OFF during the check mode, the DTC and freeze frame data will be erased.**

- (f) Start the engine (MIL goes off after the engine starts).
- (g) Simulate the conditions of the malfunction described by the customer.

### NOTICE:

**Leave the ignition switch ON until you have checked the DTC, etc.**

- (h) After simulating the malfunction conditions, use the hand-held tester diagnosis selector to check the DTC and freeze frame data, etc.

### HINT:

Be sure not to turn the ignition switch OFF, as turning it OFF switches the diagnosis system from the check mode to the normal mode, which erases all the DTCs, etc.

- (i) After checking the DTC, inspect the applicable circuit.

### 2. CLEAR DTC (Using the OBD II scan tool or hand-held tester)

- (a) Connect the OBD II scan tool or hand-held tester to the DLC3.
- (b) Turn the ignition switch ON.
- (c) When operating the OBD II scan tool (complying with SAE J1978) or the hand-held tester to erase the codes, the DTCs and freeze frame data will be erased. (See the OBD II scan tool's instruction book for operating instructions.)

3. **CLEAR DTC (Not using the OBD II scan tool or hand-held tester)**
  - (a) Disconnect the battery terminal or remove the EFI fuse from the engine room R/B for more than 60 seconds.