

DTC	C0210/33	RIGHT REAR SPEED SENSOR
DTC	C0215/34	LEFT REAR SPEED SENSOR CIRCUIT
DTC	C1238/38	FOREIGN MATTER IS ATTACHED ON TIP OF RIGHT REAR SENSOR
DTC	C1239/39	FOREIGN MATTER IS ATTACHED ON TIP OF LEFT REAR SENSOR

CIRCUIT DESCRIPTION

Refer to DTC C0200/31, C0205/32, C1235/35, C1236/36 on page 05-286.

DTC No.	DTC Detecting Condition	Trouble Area
C0210/33 C0215/34	Detection of any of conditions 1. through 3.: 1. At vehicle speed of 10 km/h (6 mph) or more, pulses are not input for 15 sec. 2. Momentary interruption of the speed sensor signal occurs at least 7 times in the time between switching the ignition switch ON and switching it OFF. 3. The condition that the speed sensor signal circuit is open continues for 0.5 sec. or more.	<ul style="list-style-type: none"> • Right rear and left rear speed sensor • Each speed sensor circuit • Speed sensor rotor
C1238/38 C1239/39	At the vehicle speed of 20 km/h (12 mph) or more, the condition that noise is included in the speed sensor signal continues for 5 sec. or more.	<ul style="list-style-type: none"> • Right rear and left rear speed sensor • Speed sensor rotor

HINT:

- DTC Nos. C0210/33 and C1238/38 are for the right rear speed sensor.
- DTC Nos. C0215/34 and C1239/39 are for the left rear speed sensor.

WIRING DIAGRAM

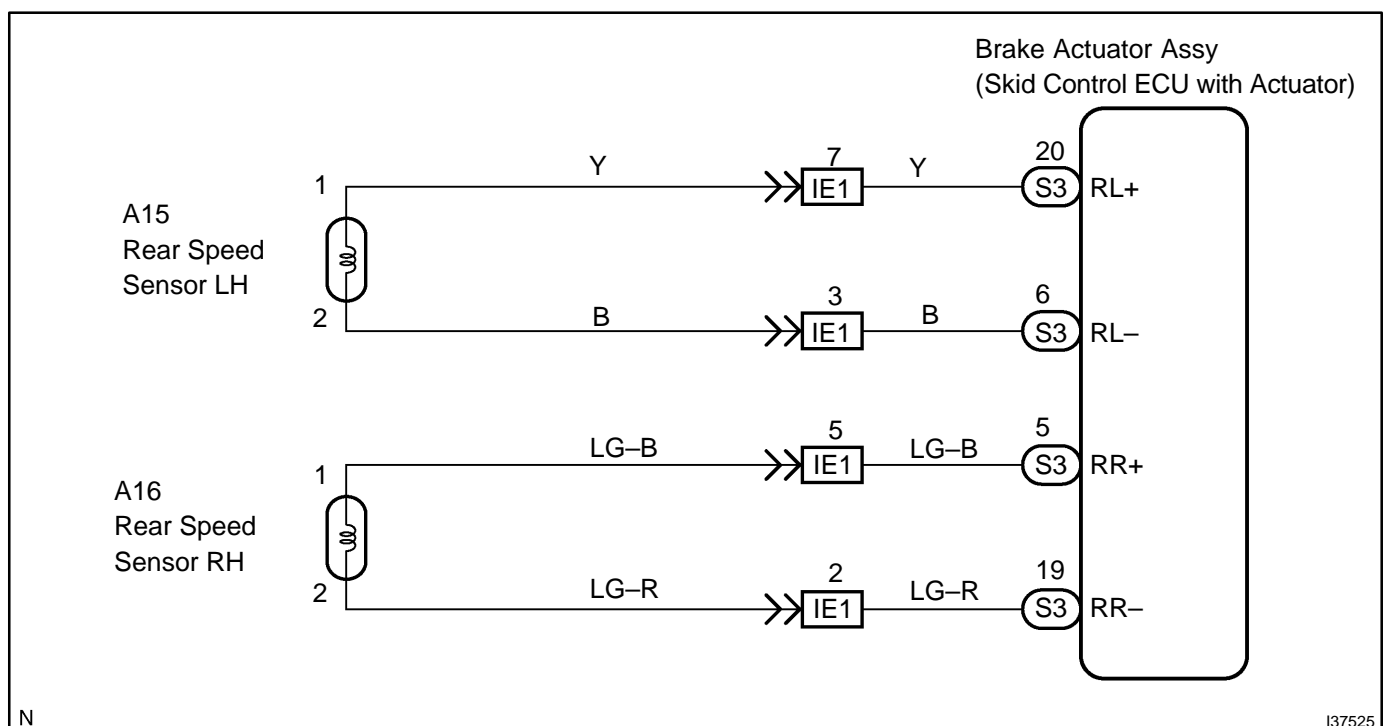

INSPECTION PROCEDURE

HINT:

Start the inspection from step 1 in case of using the hand-held tester and start from step 2 in case of not using the hand-held tester.

1 READ VALUE OF HAND-HELD TESTER(REAR SPEED SENSOR)

- (a) Connect the hand-held tester to the DLC3.
- (b) Start the engine.
- (c) Select the DATA LIST mode on the hand-held tester.
- (d) Check that there is no difference between the speed value output from the speed sensor displayed on the hand-held tester and the speed value displayed on the speedometer when driving the vehicle.

Standard:

There is almost no difference in the displayed speed value.

HINT:

There is tolerance of ± 10 % in the speedometer indication.

NG Go to step 4

OK

2 INSPECT REAR SPEED SENSOR

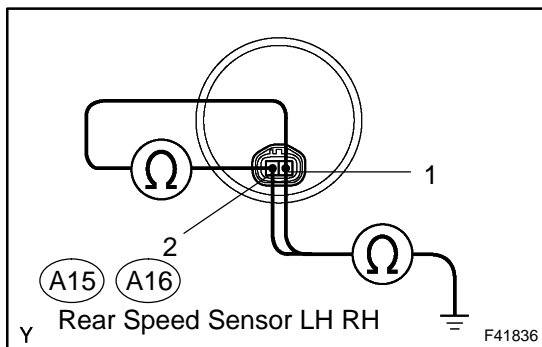

- (a) Disconnect the rear speed sensor connector.
- (b) Measure the resistance according to the value(s) in the table below.

Standard:

Tester Connection	Specified Condition
1 - 2	1.0 to 1.3 kΩ at 20 °C

- (c) Measure the resistance according to the value(s) in the table below.

Standard:

Tester Connection	Specified Condition
RL+ (A15-2) - Body ground	10 kΩ or higher
RL- (A15-1) - Body ground	
RR+ (A16-2) - Body ground	
RR- (A16-1) - Body ground	

NG REPLACE REAR SPEED SENSOR

NOTICE:

Check the speed sensor signal after replacement (See page 05-269).

OK

3 CHECK HARNESS AND CONNECTOR(REAR SPEED SENSOR – SKID CONTROL ECU)

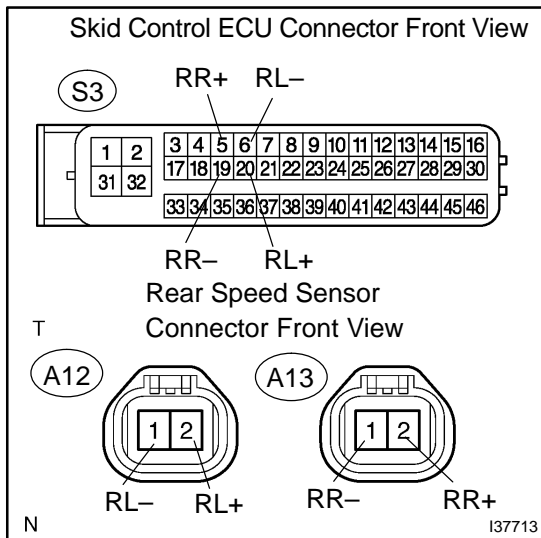

- (a) Disconnect the skid control ECU connector and the rear speed sensor connector.
- (b) Measure the resistance according to the value(s) in the table below.

Standard:

Tester Connection	Specified Condition
RL+ (S3-20) – RL+ (A12-2)	1 Ω or less
RL- (S3-6) – RL- (A12-1)	
RR+ (S3-5) – RR+ (A13-2)	
RR- (S3-19) – RR- (A13-1)	

- (c) Measure the resistance according to the value(s) in the table below.

Standard:

Tester Connection	Specified Condition
RL+ (A12-2) – Body ground	10 kΩ or higher
RL- (A12-1) – Body ground	
RR+ (A13-2) – Body ground	
RR- (A13-1) – Body ground	

NG → **REPAIR OR REPLACE HARNESS OR CONNECTOR**

OK

4 INSPECT SENSOR AND SENSOR ROTOR SERRATIONS

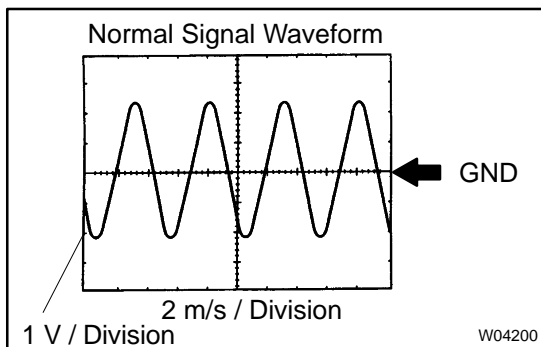

(REFERENCE) INSPECTION USING OSCILLOSCOPE

- (a) Connect the oscilloscope to the terminals RR+ – RR- and RL+ – RL- of the skid control ECU.
- (b) Drive the vehicle at about 20 km/h (12 mph), and check the signal waveform.

Standard:

Output the voltage waveform that is higher than the specified value.

HINT:

- As the vehicle speed (wheel revolution speed) increases, a cycle of the waveform becomes shorter and the fluctuation in the output voltage becomes greater.
- When noise is identified in the waveform on the oscilloscope, error signals are generated due to the speed sensor rotor's scratches, looseness or foreign matter deposited on it.

NG → **Go to step 5**

OK

REPLACE BRAKE ACTUATOR ASSY (See page 32-39)

NOTICE:

When replacing the brake actuator assy, perform the zero point calibration (See page 05-279).

5 INSPECT SENSOR INSTALLATION

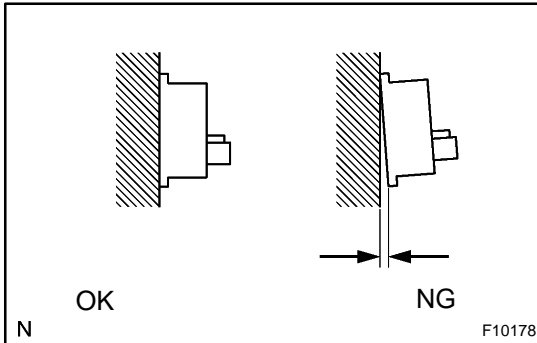

- (a) Check the sensor installation.

Standard:

There is no clearance between the sensor and rear axle carrier.

NG

REPLACE REAR SPEED SENSOR

NOTICE:

Check the speed sensor signal after replacement (See page 05-269).

OK

6 INSPECT SPEED SENSOR TIP

- (a) Remove the rear speed sensor.
 (b) Check the sensor tip.

Standard:

No scratches or foreign objects on the sensor tip.

NG

CLEAN OR REPAIR SPEED SENSOR

NOTICE:

Check the speed sensor signal after replacement (See page 05-269).

OK

7	INSPECT SENSOR ROTOR
----------	-----------------------------

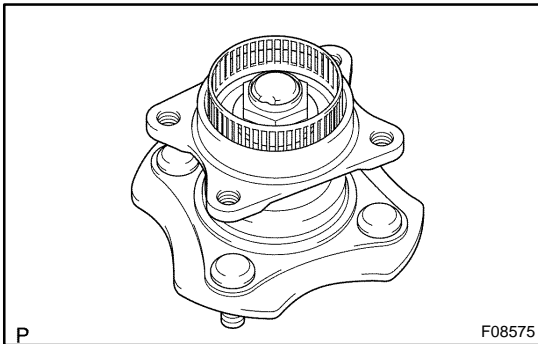

- (a) Remove the axle hub and disconnect the rear speed sensor.

Standard:

No scratches, missing teeth or foreign objects.

NG	REPLACE REAR AXLE HUB & BEARING ASSY RH
-----------	--

NG	REPLACE REAR AXLE HUB & BEARING ASSY LH
-----------	--

NOTICE:

Check the speed sensor signal after replacement (See page [05-269](#)).

OK

REPLACE BRAKE ACTUATOR ASSY (See page 32-39)

NOTICE:

When replacing the brake actuator assy, perform the zero point calibration (See page [05-279](#)).