

| | | |
|------------|-----------------|---|
| DTC | C1246/46 | MALFUNCTION IN MASTER CYLINDER PRESSURE SENSOR |
|------------|-----------------|---|

CIRCUIT DESCRIPTION

Master cylinder pressure sensor is connected to the skid control ECU in the actuator.

| DTC No. | DTC Detecting Condition | Trouble Area |
|----------|---|--|
| C1246/46 | <ul style="list-style-type: none"> When the vehicle speed is 7 km/h (4 mph) or more and PMC terminal voltage of skid control ECU exceeds 0.86 V, the condition that the voltage does not change by 0.005 V or more continues for 30 sec. Noise in terminal PMC of skid control ECU occurs 7 times or more within 5 sec. When the stop lamp switch is OFF, the condition that PMC terminal voltage of skid control ECU is 0.86 V or more, or less than 0.3 V continues for 5 sec. or more. When IG1 terminal voltage is 9.5 to 17.2 V, the condition that the VCM terminal voltage of skid control ECU is out of the range from 4.4 to 5.6 V continues for 1.2 sec. or more. When VCM terminal voltage of skid control ECU is 4.4 to 5.6 V, the condition that the PMC terminal voltage of skid control ECU is out of the range from 0.14 to 4.85 V continues for 1.2 sec. or more. | <ul style="list-style-type: none"> Master cylinder pressure sensor Master cylinder pressure sensor circuit |

INSPECTION PROCEDURE

| | |
|----------|--|
| 1 | READ VALUE OF HAND-HELD TESTER(MASTER CYLINDER PRESSURE SENSOR) |
|----------|--|

- Connect the hand-held tester to the DLC3.
- Select the DATA LIST mode on the hand-held tester.
- Check that the brake fluid pressure value of the master cylinder pressure sensor observed in the hand-held tester changes when the brake pedal is depressed.

| Item | Measurement Item / Range (Display) | Normal Condition | Diagnostic Note |
|-----------------|--|--|---|
| MAS CYL PRESS 1 | Master cylinder pressure sensor 1 reading/min.: 0 V, max.: 5 V | When brake pedal is released: 0.3 to 0.9 V | Reading increases when brake pedal is depressed |

Standard:

Brake fluid pressure value (voltage) should change.

NG →

Go to step 2

OK

REPLACE BRAKE ACTUATOR ASSY (See page 32-39)

NOTICE:

When replacing the brake actuator assy, perform the zero point calibration (See page 05-279).

2 INSPECT SKID CONTROL ECU TERMINAL VOLTAGE(STP TERMINAL)

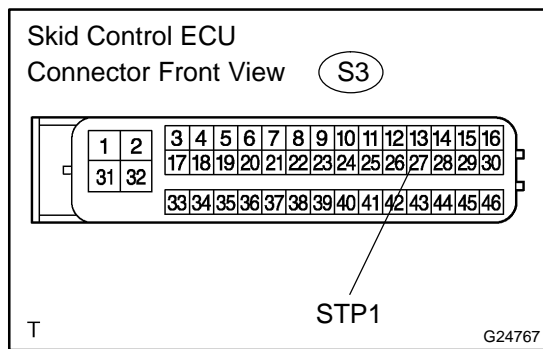

- (a) Disconnect the skid control ECU connector.
- (b) Measure the voltage according to the value(s) in the table below.

Standard:

| Tester Connection | Condition | Specified Condition |
|----------------------------|--------------------------|---------------------|
| STP1 (S3-27) - Body ground | Brake pedal is depressed | 8 to 14 V |

- (c) Measure the voltage according to the value(s) in the table below.

Standard:

| Tester Connection | Condition | Specified Condition |
|----------------------------|-------------------------|---------------------|
| STP1 (S3-27) - Body ground | Brake pedal is released | 1 V or less |

NG → **CHECK AND REPLACE STOP LIGHT SWITCH CIRCUIT**

OK

REPLACE BRAKE ACTUATOR ASSY (See page 32-39)

NOTICE:

When replacing the brake actuator assy, perform the zero point calibration (See page 05-279).